

450NK

OWNER'S MANUAL

READ THIS MANUAL CAREFULLY

It contains important safety information. Make sure operator holds a valid driver license.
Passengers under 12 are prohibited.

TABLE OF CONTENTS

FOREWORD	8
Welcome	8
EVAP System (Evaporative Emission Control System)	9
Key Signals	10
VIN AND SERIAL NUMBER	12
SPECIFICATIONS	13
OPERATOR SAFETY	16
General Safety Precautions	16
Equipment Modifications	17
Owner Responsibilities.....	20
Safe Riding Gear.....	21
AVOID DANGEROUS RIDING BEHAVIORS	24
VEHICLE VIEW	28
Left View.....	28
Right View	29
Top View.....	30
OPERATING PARTS	31
Clutch Lever	31

Front Hand Brake Lever	31
Handlebar Switch, LH	32
Handlebar Switch, RH	33
Throttle Grip	33
Locks	34
Gear Shift Lever	35
Rear Brake Lever	36
Side Stand	36
Passenger Handhold and Footrests	37
INSTRUMENT	38
Activation and Testing	38
Instrument Indicators	39
Instrument Display	42
Instrument Menu	48
OPERATING YOUR VEHICLE	75
Break-in Period	75
Daily Safety Inspection	76
Starting	78
Starting Off	79
Shifting, Riding	79

Brake	81
Parking	82
SAFETY OPERATION	83
Safe Riding Tips	83
Additional Cautions for High Speed Operation	84
MAINTENANCE	85
Improper Use	85
Key Points of Lubrication Schedule:	86
Break-in Periodic Maintenance Chart	87
After Break-in Periodic Maintenance Chart	90
CLUTCH LEVER FREE-PLAY	96
GEARSHIFT LEVER ADJUSTMENT	97
TOOL KIT	97
FUEL SYSTEM	98
Fuel Tank	98
Fuel Requirements	99
Octane Rating (RON)	99
ENGINE ASSY	100
Oil Level Inspection	100

Oil and Oil Filter Replacement	101
Oil Capacity	102
Spark Plug	103
Idling	103
AIR INTAKE AND EXHAUST SYSTEM.....	104
Exhaust Detecting System	104
Air Intake Valve	104
Valve Clearance	105
Air Filter	106
Throttle Body	106
COOLING SYSTEM.....	107
Radiator and Cooling Fan	107
Radiator Hoses	107
Coolant	108
Coolant Level Inspection	110
Coolant Replenishment	111
TIRES AND CHAINS	112
Tire Specifications	112
Tire Payload	113
Tire Friction	114

Drive Chain Inspection	115
Drive Chain Tension Adjustment	116
BRAKE SYSTEM	118
Front Brake Lever Inspection	118
Rear Brake Pedal Inspection	118
Brake Fluid Level Inspection	119
Brake Fluid Replenishment	120
Brake Disc Inspection	122
Brake Caliper Inspection	122
Anti-lock Braking System (ABS)	123
SHOCK ABSORBER	124
Shock Absorber Inspection	124
Rear Shock Absorber Adjustment	124
ELECTRICAL SYSTEM AND LIGHT SIGNALS.....	125
Battery	125
Battery Removal.....	128
Battery Mounting	129
Lights.....	130
Fuses	131
CATALYTIC CONVERTER	132

EVAPORATIVE EMISSION CONTROL SYSTEM	133
MOTORCYCLE CLEANING AND STORAGE.....	134
General Precautions	134
Washing the Vehicle.....	135
Decorating the Surface	136
Windshield and Other Plastic Parts.....	136
Chrome and Aluminum.....	136
Preparation for Storage.....	137
Preparation After Storage.....	138
COMMON PROBLEMS AND CAUSES	139
GENERAL TORQUE CHART	142
CRUCIAL TORQUE CHART	142
TELEMATICS BOX	146

FOREWORD

Welcome

Thank you for purchasing a CFMOTO vehicle, and welcome to our world-wide family of CFMOTO enthusiasts. Be sure to visit us online at www.cfmoto.com for the latest news, new product introductions, upcoming events, and more.

CFMOTO is an international company that specializes in the development, manufacture, and marketing of all-terrain vehicles, utility vehicles, large displacement motorcycles, and their core components. Founded in 1989, CFMOTO is devoted to the development of independent brand cultivation and R&D innovation.

CFMOTO products are currently distributed through more than 2000 companions worldwide in more than 100 countries and regions. CFMOTO is edging into the advanced ranks in the world of powersports, and aims to supply superior products to dealers and fans globally.

For safe and enjoyable operation of your vehicle, be sure to follow the instructions and recommendations in this owner's manual. Your manual contains instructions for minor maintenance. Information about major repairs is outlined in the CFMOTO Service Manual.

Your CFMOTO dealer knows your vehicle best and is interested in your total satisfaction. Be sure to return to your dealership for all of your service needs during, and after, the warranty period.

Due to constant improvements in the design and quality of production components, some minor discrepancies may result between the actual vehicle and the information presented in this publication.

Depictions and/or procedures within are intended for reference use only.

Before every ride, please inspect your vehicle and follow the basic maintenance procedures before riding. Please keep this manual together with your vehicle, even when transferring the vehicle to others.

Zhejiang CFMOTO power Co., Ltd reserves the final explanation rights of the owner's manual.

Depictions and/or procedures within are intended for reference use only. The content in this publication is based on the latest production information available at the time of approval for printing.

CFMOTO reserves the right to make changes at any time without notice and without incurring any obligation.

This manual is for the following vehicles: CF400-7F CF400-7

 **DANGER**

Operating, servicing and maintaining on-road or off-road vehicles can expose you to chemicals including engine exhaust, carbon monoxide, phthalate, and lead, which are known to cause cancer and birth defects or other reproductive harm. To minimize exposure, avoid breathing exhaust, do not idle the engine except as necessary, service your vehicle in a well-ventilated area and wear gloves or wash your hands frequently when servicing your vehicle.

EVAP System (Evaporative Emission Control System)

(If equipped)

When required by environmental emissions regulations, this vehicle is manufactured with a fuel evaporation system (EVAP) to prevent fuel vapors entering the atmosphere from the fuel tank and fuel system.

During routine maintenance, visually inspect all hose connections for leaks or blockage. Ensure the hoses are not clogged or kinked, which could damage the fuel pump or distort the fuel tank. No other maintenance is necessary.

Key Signals

Warning signals call attention to the safety signal or other signals, as well as the performance default signal or other signals. They also specify the danger's severity. This manual's standard signals are: "DANGER", "WARNING", "CAUTION" and "NOTE".

The following signal words and symbols appear throughout this manual and on your vehicle. Your safety is at risk when these words and symbols appear on your vehicle. Please be familiar with their meanings when reading the manual:

 DANGER

Indicating that it may cause deaths to operators or people around, if no measures are taken.
--

 WARNING
--

Indicating that it may hurt operators or damage components, if no measures are taken.

 CAUTION
--

Indicating that to prevent components from being damaged, precautionary measures should be taken.

NOTE:

Indicating that there are easier or clearer information for operation. No signal is used in this circumstance.

**READ THE OWNER'S MANUAL
FOLLOW ALL INSTRUCTIONS AND WARNINGS**

 WARNING

Read, understand, and follow all of the instructions and safety precautions in this manual and on all product labels. Failure to follow the safety precautions could result in serious injuries or deaths.

 WARNING

The engine exhaust gas from this product contains CO, which is deadly and can cause headaches, giddiness, loss of consciousness, or even death.

VIN AND SERIAL NUMBER

Please record the VIN number, motor serial number and nameplate at the position indicated on the following illustration.

VIN:

Motor Serial Number:

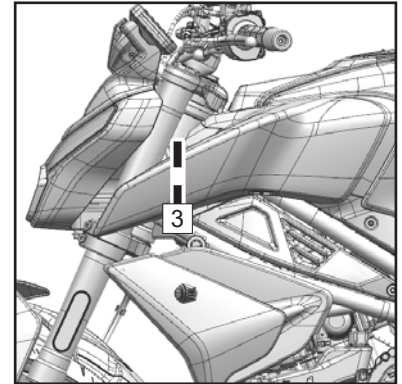
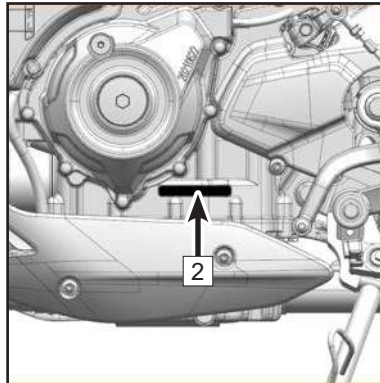
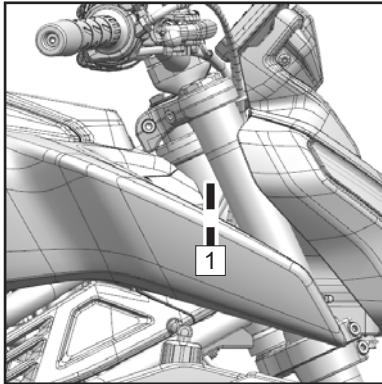

1	VIN	2	Engine Serial Number	3	Vehicle Plate
---	-----	---	----------------------	---	---------------

SPECIFICATIONS

	450NK	
	CF400-7F	CF400-7
Performance		
Max power	46.3 Hp (34.5 Kw) / 10000 rpm	49.6 Hp (37 Kw) / 9500 rpm
Max torque	28.9 Ft-lb (39.3 N•m) / 7750 rpm	28.8 Ft-lb (39 N•m) / 7600 rpm
Min. turn diameter	16 ft (5 m)	
Top designed speed	110 mph (178 km/h)	
Size		
Length	78.3 in (1990 mm)	78.7 in (2000 mm)
Width	31.9 in (810 mm)	
Height	44.5 in (1130 mm)	
Wheelbase	53.7 in (1365 mm)	53.9 in (1370 mm)
Seat height	31.3 in (795 mm)	
Ground clearance	7.6 in (192 mm)	
Curb weight	363.8 lb (165 kg)	
Engine		
Type	Twin cylinder in parallel, four stroke, liquid cooled	
Displacement	449 mL	
Bore×stroke	2.83 in × 2.17 in (72 mm × 55.2 mm)	
Compression ratio	11.5 : 1	
Starting system	Electric starter	

Fuel supplying system	EFI	
Ignition control system	ECU Ignition	
Lubricating system	Pressure splash	
Oil capacity	2.64 qt (2.5 L)	
Engine oil type	SAE 10W-40 SJ or higher JASO MA2	
Coolant capacity	40.6 oz (1200 mL) + about 6.8 oz (200 mL) (Reservoir)	
Idle speed	1350 r/min \pm 135 r/min	1400 r/min \pm 140 r/min
Transmission		
Transmission type	6-speed, international standard gear	
Clutch type	Wet, multi disc, sliding clutch	
Driving system	Chain drive	
Primary reduction ratio	2.088	
Final reduction ratio	2.929	
Gear ratio	1 st	2.929
	2 nd	2.056
	3 rd	1.579
	4 th	1.333
	5 th	1.154
	6 th	1.037
Chassis		
Tire size	Front	110 / 70 R17 M/C 54H
	Rear	150 / 60 R17 M/C 66H

Rim size	Front	MT 3.0 × 17	
	Rear	MT 4.0 × 17	
Capacity of fuel tank	3.7 gal (14 L) ± 0.13 gal (0.5 L)		
Average fuel consumption per 100 Km	≤1.2 gal (4.5 L)		≤1.3 gal (4.8 L)
Electric components			
Battery	12 V 12 Ah		
Headlight	LED		
Turning light	LED		
Tail light	LED		

OPERATOR SAFETY

General Safety Precautions

WARNING

Please read this manual carefully before operating the vehicle and understand all safety warnings, precautions and operating procedures.

Age Limit

This model is for adults only. The operator must acquire a driving license as required by local laws and regulations, and children under the age of 12 are not allowed to ride CFMOTO's passenger-carrying vehicles.

Know Your Vehicle

As the operator of the vehicle, you are responsible for your personal safety, the safety of others, and the protection of the environment. Read and understand your owner's manual, which includes valuable information about all aspects of your vehicle, including safe operating procedures.

Equipment Modifications

CFMOTO is concerned with the safety of our customers and of the general public. Therefore, we strongly recommend that consumers should not mount on a vehicle, any equipment that may increase the speed or power of the vehicle, or make any other modifications to the vehicle for these purposes. Any modifications to the original equipment of the vehicle create substantial safety hazards and increase the risk of body injury. The warranty on your vehicle is terminated if any unapproved accessory equipment has been added to the vehicle, or if any modifications have been made to the vehicle that increase its speed or power.

NOTE:

Any specific equipment that may change the handling and performance of the vehicle, including but not limited to side boxes, exhaust, side wheels, etc. Use only approved equipment and familiarize yourself with their functions and roles on the vehicle.

Avoid Carbon Monoxide Poisoning

All engine exhaust contains carbon monoxide, a deadly gas. Breathing carbon monoxide can cause headaches, dizziness, drowsiness, nausea, giddiness and even death. Carbon monoxide is a colorless, odorless, tasteless gas that may be present even if you do not see or smell any engine exhaust. Deadly levels of carbon monoxide can accumulate rapidly, and you can quickly be overcome and unable to save yourself. Also, deadly concentration of carbon monoxide can remain for hours or days in enclosed or poorly ventilated areas.

To prevent serious injury or death from carbon monoxide:

- Never run the vehicle in poorly ventilated or partially enclosed areas.
- Never run the vehicle outdoor where engine exhaust can be drawn into a building through openings such as windows and doors.

Avoid Gasoline Fires and Other Hazards

Gasoline is extremely flammable and highly explosive. Fuel vapors can spread and be ignited by a spark or flame many feet away from the engine. To reduce the risk of fire or explosion, follow these instructions:

- Use an approved gasoline tank to store fuel.
- Strictly adhere to proper fueling procedures.
- Never start or operate the engine if the fuel cap is not properly mounted. Gasoline is poisonous and can cause injury or death.
- Never siphon gasoline by mouth.
- If you swallow gasoline, get any in your eye (s) , or inhale gasoline vapor, see a doctor immediately.
- If gasoline spills on you, wash with soap and water and change your clothes.

Fuel Minimum Octane Rating and Safety Warnings

The recommended fuel for your vehicle is E5 or 95(RON). Non-oxygenated (ethanol-free) fuel is recommended for best performance in all conditions.

 **WARNING**

Gasoline is highly flammable and explosive under certain conditions. Allow the engine and exhaust system to cool before filling the tank. Always be highly cautious whenever handling gasoline. Always refuel the vehicle when the engine stopped outdoors or in well-ventilated areas. Do not smoke or allow open flames or sparks in or near the area where refueling is performed, or where gasoline is stored.

Do not overfill the tank. Do not fill oil to the tank neck.

If gasoline spills on your skin or clothing, immediately wash it off with soap and water and change clothing. Never start the engine or let it run in an enclosed area. Engine exhaust fumes are poisonous and can cause loss of consciousness or death in a short time. The engine exhaust from this product contains chemicals known to cause cancer, birth defects or other reproductive harm. Operate this vehicle only outdoors or in well-ventilated areas.

Avoid Burns From Hot Parts

The exhaust system and engine become hot during operation. Avoid touching them during and shortly after operation to avoid burns.

Owner Responsibilities

Be Qualified and Responsible

Read this Owner's Manual and the warning labels on this vehicle carefully. Take a safety training course on open areas if possible and practice at low speed. Higher speed requires greater experience, knowledge and suitable riding conditions. Be familiar with the control technology and the general operations of the vehicle.

This vehicle is an ADULT VEHICLE ONLY. The operator must acquire a driving license as required by local laws and regulations. Operators must be tall enough with physical capacity to: be properly seated, hold the handlebar with both hands, fully operate the clutch lever with the left hand, fully operate the brake lever with the right hand, fully operate the foot brake lever with the right foot, be able to firmly put both feet on the foot pegs, and be able to balance the vehicle with the feet when stopped and seated.

Carrying a Passenger

- Only carry one passenger. The passenger must be properly seated in the passenger seat.
- The passenger should be over 12 and be tall enough to always be properly seated when holding handhold, and feet firmly put on the foot pegs.
- Never carry a passenger who has used drugs or alcohol, or is tired or ill. These slow reaction time and impair judgment.
- Instruct the passenger to read the vehicle's safety labels.
- Never carry a passenger if you think that their ability or judgment is insufficient to concentrate on the terrain conditions and adapt accordingly.

Safe Riding Gear

Always wear clothing suited to the type of riding for the driver and passenger, includes:

1. An approved helmet
2. Goggles
3. Gloves
4. Long-sleeved shirts or jackets
5. Long pants
6. Over-the-ankle boots

According to the actual weather, you may need extra apparel, such as anti-fog goggles, thermal underwear and a face guard for cold weather. The operator must never wear loose clothing that may get entangled in the vehicle or on tree branches and shrubs.

Helmets and Goggles

An approved helmet can prevent a serious head injury if an accident occurs. Please note that even the best helmet is no guarantee against injury.

The helmet you choose should meet the standard for your country or area and its size should suit you. A closed-face helmet with face shield will be better at preventing impacts from insects, flying rocks, dust and scattered debris, etc.

An open-face helmet can not offer the same protection for your

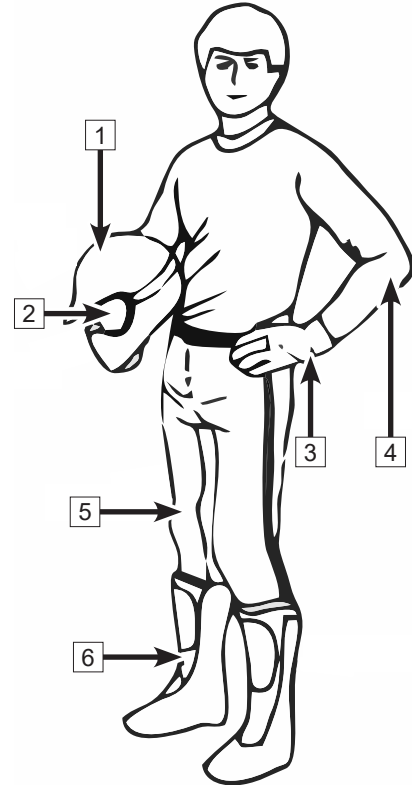

face and jaw. Please wear detachable face masks and goggles when wearing an open-face helmet.

Do not depend on eyeglasses or sunglasses for enough eye protection, as they may fly out or shatter in case of an accident to cause second damage, and they can not prevent wind and airborne objects from getting into eyes.

Use tinted masks or goggles only during the day in bright light, do not use them at night or in poor light. They may affect your ability to distinguish colors. Do not use them if your color discrimination is affected.

Gloves

Full-finger gloves could protect your hands from wind, sun, heat, cold, and splash. Well-fitted gloves are helpful for steering and relieving hand fatigue. If the gloves are too heavy, it will be difficult to operate the vehicle.

A pair of strong motorcycle gloves offers protection for your hands in the event of an accident or turnover. Snowmobile gloves offer better protection when operating in cold areas.

Jackets, Pants and Motorcycle Suits

Wear a jacket or a long-sleeved shirt and long pants, or a full set of riding suit. Quality protective gear will provide comfort, and it can help you avoid being distracted by adverse environmental elements. In case of an accident, good quality protective gear made of sturdy material may prevent or reduce injury.

When riding in a cool weather, protect yourself against hypothermia which is a state of low body temperature and can cause loss of concentration, slowed reactions and loss of smooth, precise muscle movement. In cool conditions, proper protective gear like a windproof jacket and insulated layers of clothing are essential. Even while riding at moderate temperatures, you can feel very cold due to the wind.

Protective gear that is appropriate for cold-weather riding may be too hot when the vehicle is stopped.

Dress in layers so that clothing can be removed as desired. Topping the protective gear with a windproof outer layer can prevent cold air from reaching the skin.

Boots

Always wear closed-toe, over-the-ankle boots. Sturdy over-the-ankle boots with non-slip soles offer more protection, and allow you to put your foot properly on the foot pegs. Avoid long shoelaces that could get entangled in the vehicle components. In winter, rubber-soled boots with either nylon or leather uppers and removable felt liners are best suited. Avoid rubber boots which may get trapped behind or in the foot brake pedal, impairing proper operation.

Other Riding Gear

Rain Gear

When riding in rainy weather, a rain suit or a waterproof riding suit is recommended. On long rides, it is a good idea to carry rain gear. Keeping clothes is beneficial for keeping operators being much more comfortable and alert.

Hearing Protection

Long-term exposure to wind and engine noise when riding can cause permanent hearing loss. Properly worn hearing protective gear such as earplugs can help prevent hearing loss. Check local laws before using any hearing protective gear.

AVOID DANGEROUS RIDING BEHAVIORS

The following behaviors may cause serious consequences, so instructions must be followed to avoid dangerous behaviors.

Wrong Operations

⚠️WARNING: Wrong operations may cause serious damage to the operator, passenger and people around.

Read every instruction in this manual and be familiar with every function of this vehicle. Must participate in the safety training and know how to operate the vehicle properly in different situations and on different types of terrain.

Age Limit

⚠️WARNING: It is restricted to allow people under 18 to ride the vehicle and people under 12 to be passengers.

Severe injury and/or death could occur if a child under the minimum age limit operates this vehicle. Even though a child may be within the recommended age group for operating, he/she may not have the skills, abilities, or judgment needed to operate safely and could be susceptible to accidents or injuries. The vehicle can only be operated by people over 18 years old and with safe driving skills and the driver's license.

Illegal Carrying

⚠️WARNING: It is restricted to carry the passengers more than allowed.

Carrying the passengers more than allowed is illegal and will much affect the vehicle's riding performance and may cause serious accidents.

Riding on Unpaved Roads

⚠️WARNING: The vehicle must not ride on unpaved roads.

The tires of this car are designed to drive on paved roads, not suitable for use on unpaved roads such as sand, mud, puddles and dirt roads. Driving on unpaved roads will seriously affect vehicle handling, which will greatly increase the incidence of accidents. If it is impossible to avoid short periods of driving on unpaved roads, reduce your speed and ensure that you do not make sharp turns, sudden braking, etc.

Safe Riding Gear

⚠️WARNING: Must wear an approved helmet, goggles and protective clothing when riding.

Unapproved helmets increase the risk of head injury and death in the event of an accident; Failure to use goggles increases the risk of eye injury and death in the event of an accident; Always wear a whole set of gear to reduce accidents and increase your own protection.

Drinking and Medication

⚠️WARNING: Do not operate a vehicle under the influence of alcohol, medication or drugs.

Drinking, taking medication and taking drugs will seriously affect drivers' judgment and reaction ability, as well as their perception and balance, which will greatly increase the incidence of accidents. Do not operate vehicles after drinking, taking medication or taking drugs.

Speeding

⚠️WARNING: No speeding.

Speeding increases the risk of losing control of the vehicle, leading to accidents. Choose your driving speed based on vehicle load, terrain, visibility, driving conditions, and never exceed the maximum speed.

Stunts

⚠️WARNING: Do not try stunts.

All stunts are dangerous, including but not limited to slippery tires, jumping, side-slip, front wheel upturn, etc. Stunt or demonstration riding can result in serious accidents. Always use normal driving methods.

Inspections and Maintenance

⚠️WARNING: Check vehicle's conditions before driving and maintaining vehicle regularly.

Checking vehicle's conditions before driving can reduce the probability of accidents. Maintain the vehicle regularly to ensure the equipment is in good condition. Please follow the instructions for inspection and before driving and regular maintenance.

Lift Hands and Feet From the Vehicle

⚠️WARNING: Do not lift your hands off the handlebars or your feet off the pedals when driving.

Even leaving with only one hand or foot can reduce your ability to control the vehicle or cause you to lose your balance and fall off from the vehicle. If the driver's feet are not firmly put on the pedal, they may be unable to operate the brake or accelerator in time or may be influenced by external environmental factors, resulting in an accident.

Tire Size

⚠️WARNING: Do not use tires with wrong gauge, wrong tire pressure or uneven tire pressure.

Wrong tires may cause accidents. It is forbidden to use wrong tires. Check the tire pressure regularly to ensure that the tires are always within the normal pressure range.

Modifications

⚠️ WARNING: Any non-standard modifications are prohibited.

Any modifications will affect vehicle handling, which can lead to accidents. It is prohibited to mount any equipment which would increase the speed or power of the vehicle, or to make any other modifications to the vehicle for these purposes. All equipment and accessories added to the vehicle must be original or designed for use on the vehicle.

Keys

⚠️ WARNING: Do not leave keys on the vehicle. Lock the stem lock before leaving the vehicle.

Keys left on the vehicle may result in unauthorized use of the vehicle, causing an accident or property damage, so please take away the key when the vehicle is not in use.

Dangerous Transportation

⚠️ WARNING: Do not transport inflammable, explosive or other dangerous goods.

Transportation of dangerous goods may cause serious injuries or accidents.

VEHICLE VIEW

Left View

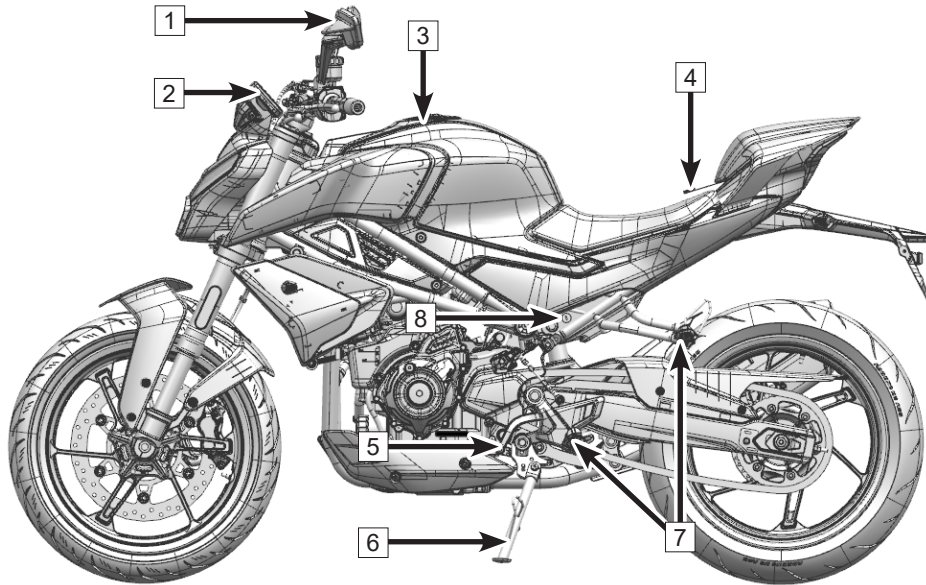

- 1: Rear View Mirror
- 2: Instrument
- 3: Fuel Tank Lock
- 4: Passenger Armrest
- 5: Gear Shift Lever
- 6: side stand
- 7: Footrest Kit
- 8: Seat lock

Right View

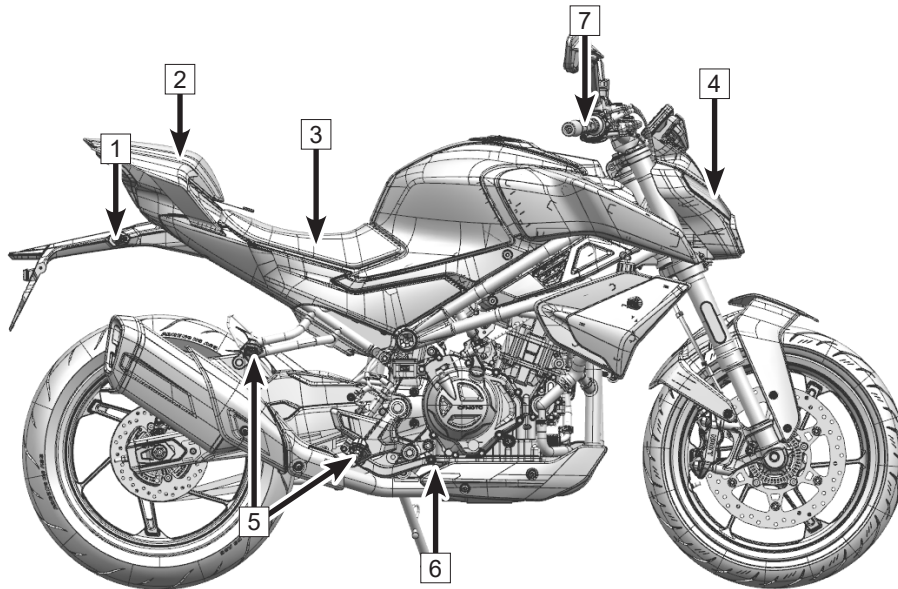

- 1: Rear Turning Lighting
- 2: Passenger Cushion
- 3: Driver Cushion
- 4: Front Lighting
- 5: Footrest Kit
- 6: Rear Brake Pedal
- 7: Throttle grip

Top View

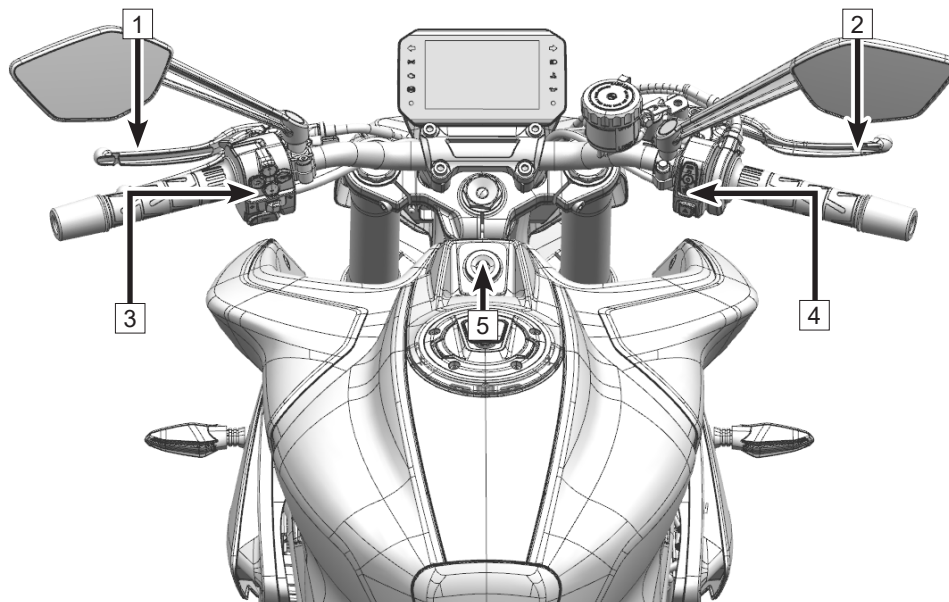

- 1: Clutch lever
- 2: Front Hand Brake Lever
- 3: Handlebar Switch, LH
- 4: Handlebar Switch, RH
- 5: Ignition switch

OPERATING PARTS

Clutch Lever

Clutch lever **1** is on the left side of handlebar. The clutch is a cable clutch.

Adjust the clutch lever's distance to the handlebar by turning the clutch lever adjusting knob.

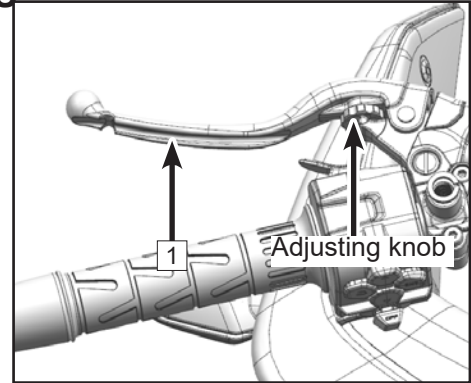

Front Hand Brake Lever

Front hand brake lever **2** is on the right side of handlebar. Front brake caliper activates braking by using the front hand brake lever.



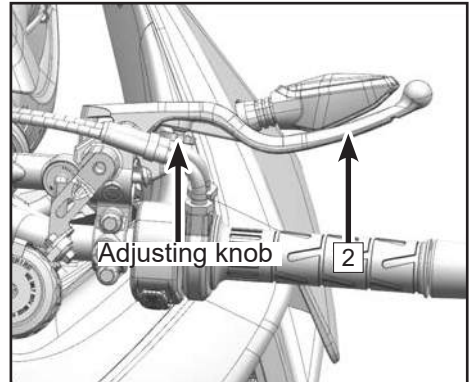



Adjust the clutch lever's distance to the handlebar by turning the clutch lever adjusting knob.



Handlebar Switch, LH

Left handlebar switch 1 is on the left side of the handlebar.

Functions of Left Handlebar Switch



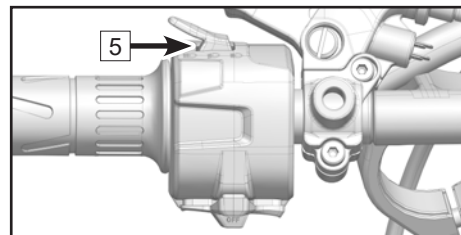
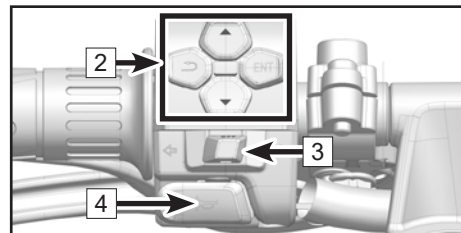
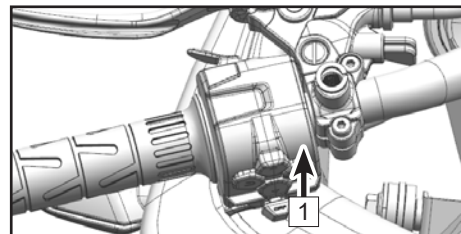

2	Instrument button		Instrument operations, please refer to INSTRUMENT.
3	Turning light switch		Push this switch to the right, the right turning light will be on.
			Push this switch to the left, the left turning light will be on.
4	Horn button		Press and the horn will sound.
5	Dimmer push switch		Press this button, passing light will flash.
			Turn to this position, high beam lights will be on.
			Turn to this position, low beam lights will be on.



Handlebar Switch, RH

Right handlebar switch **1** is on the right side of the handlebar.

Functions of Right Handlebar Switch

2	Start and stop switches	 Turn to this position, the vehicle stops.
		 Turn to this position, the vehicle is preparing for starting.
		 Turn to this position, the vehicle starts.
3	Hazard flasher switch	 Press to turn on the hazard flasher light.

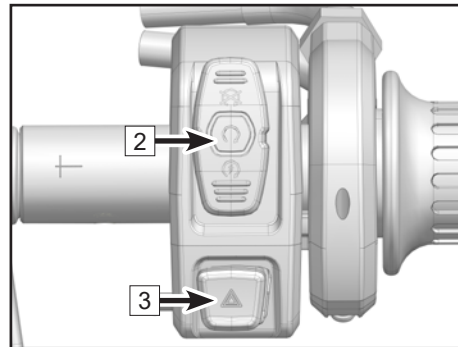
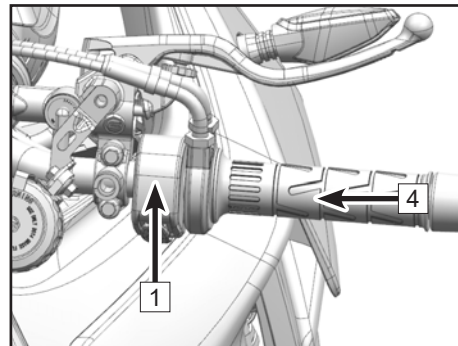

Throttle Grip

Throttle grip **4** is at the right side of the right handlebar.



Locks

Ignition switch 1

Handlebar lock		Turn the handlebar left to the end, then turn the key to the lock indicator to lock the handlebar.
Stop		Turn the key to this position, the engine cannot be started and all the vehicle's power circuits are disconnected.
Start		Turn the key to this position, the engine can be started and all the vehicle's power circuits are connected.

Fuel Tank Lock 2

Before opening the fuel tank lock: The vehicle must be stopped and the engine must be closed.

Open the fuel tank lock cover;

Insert the key and turn the key to release the lock;

Open the fuel tank cap.

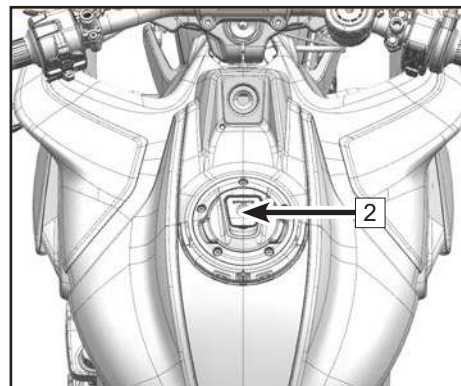
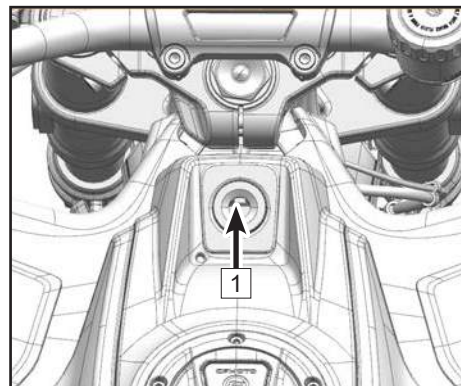

Seat Lock

The seat lock **1** is on the left side of the vehicle.

The seat can be removed by inserting the key and turning to release the lock.

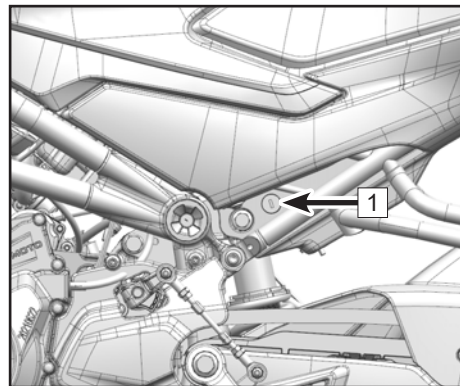

Gear Shift Lever

The gear shift lever **1** is on the left side of the engine.

The exposed length D of the screw thread at both ends of the middle connecting rod is adjustable;

D's adjusting range: 4 mm ~ 10 mm

Loosen the locking nuts at both ends **2**;

Rotate the middle connecting rod **3** to adjust the height of the shift lever;

Relock the nuts. (Torque: 4.4 ft-lb (6N•m))

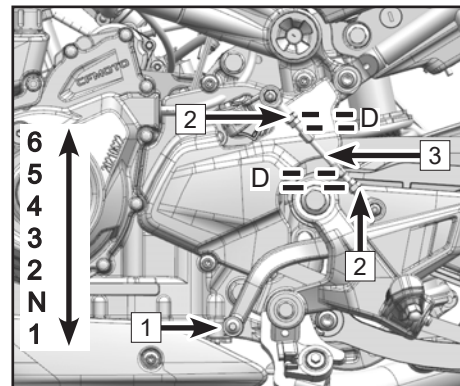

Rear Brake Lever

The rear brake lever **1** is on the right side of the engine. Step on rear brake lever to make rear brake caliper to stop the vehicle.

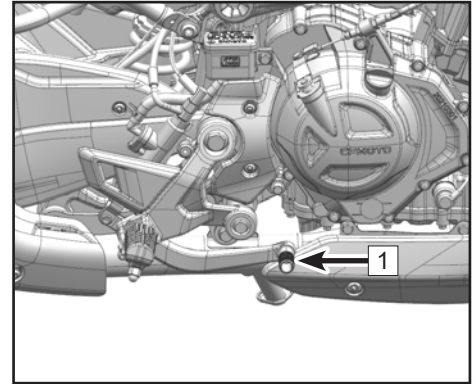

Side Stand

The side stand **2** is on the left side of the vehicle, and is used for parking;

When the side stand is lowered, the vehicle can only be started with neutral gear.

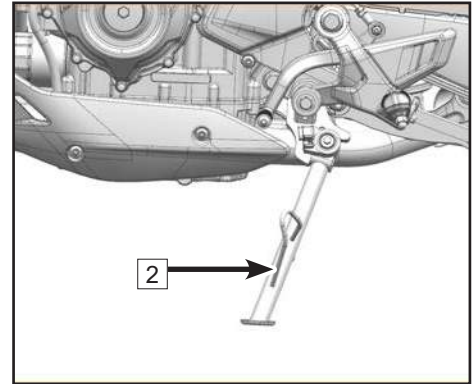

Passenger Handhold and Footrests

The passenger handhold **1** is fixed on the motorcycle and can be held by the passenger, such as a pulling belt or handle, etc.

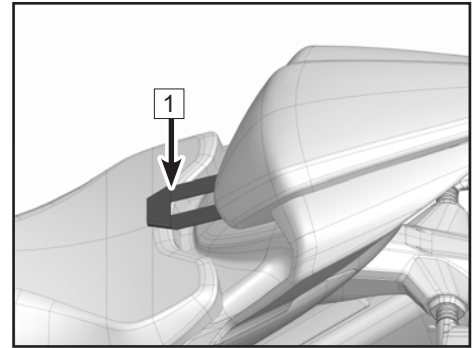

Footrests **2** are pedals or footboards fixed on the motorcycle for the operator and passenger to put their feet.

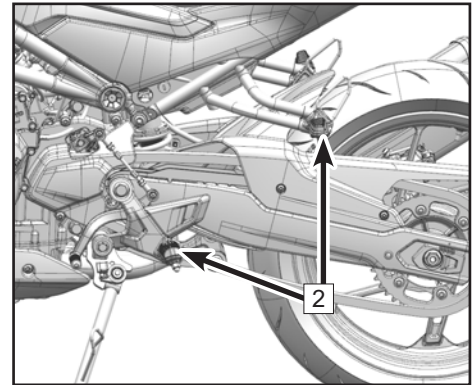

INSTRUMENT

NOTE

With function adjustment and version updates of the instrument and renewed vehicle configurations, some contents of the instrument may change, please selectively refer to this chapter according to your car.

Instrument

The instrument is mounted at the front side of the handlebar and divided into two function areas:

- 1: Instrument Indicators
- 2: Instrument Display

Activation and Testing

Activation

The instrument is activated synchronously when the motorcycle is powered on.





Testing

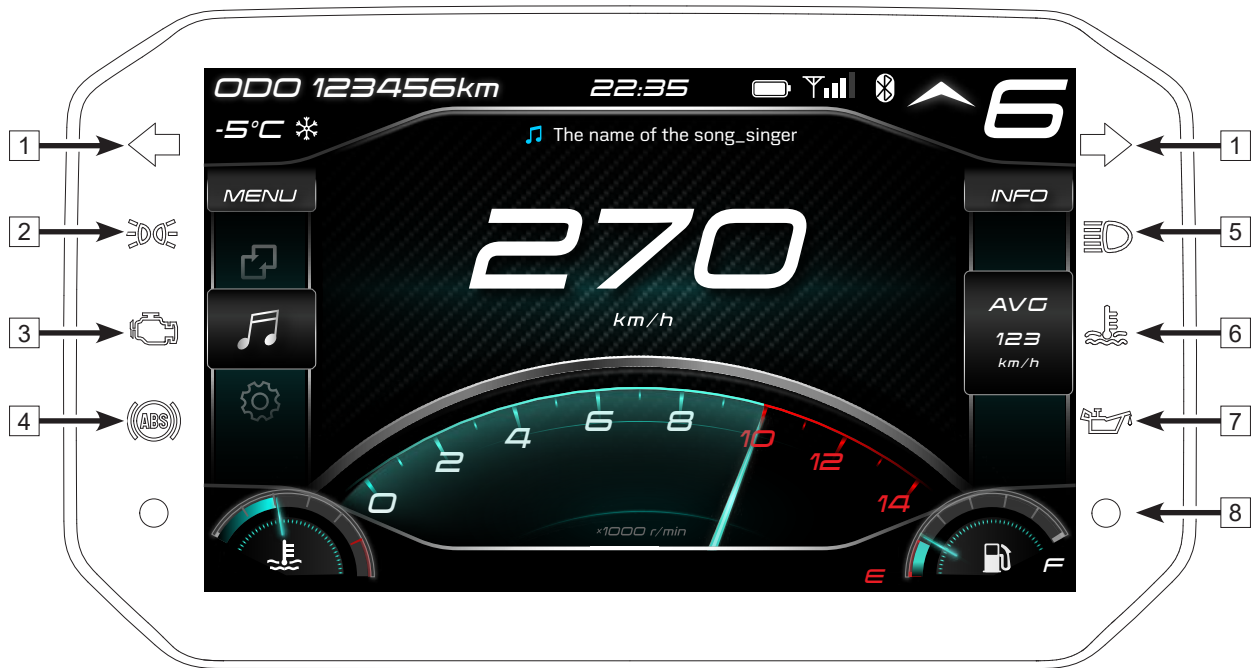

The display screen shows a startup cartoon and the indicator light is turned on for self-inspection and at this time, the button will not respond until the cartoon is over.



Instrument Indicators



Number	Symbol	State	
1		Flash	When turning signal indicators are flashing, the corresponding turning lights are on.
2		On	When the position light indicator is on, the position light is turned on.
3		On	When the vehicle is powered on and the engine is off, the fault indicator is on; if the engine is not off but the fault indicator is also on, then this means that the vehicle detects a fault in its circuit and the fault will be shown in the Instrument Indicators area. When this fault indicator is on, please park the vehicle in line with local laws and regulations, and contact an authorized CFMOTO after-service center.
4		On	If ABS system works normally, it will be on when the vehicle is in parking state or low-speed riding, which is a normal phenomenon. If there is any ABS fault, ABS indicator will be on, and at this time, the ABS system will stop working, but general braking functions may still play their roles. Please reduce the speed and avoid sudden braking and timely contact an authorized CFMOTO after-service center.
5		On	When the high beam indicator is on, the high beam light is turned on.

6		On	<p>When the coolant temperature is higher than 115°C, the Coolant temperature warning indicator will be turned on. Please park the vehicle according to local laws and regulations to wait for the temperature drop. And if this indicator is turned on frequently, contact an authorized CFMOTO after-service center.</p>
7		On	<p>When Oil pressure indicator is on, the oil level is very low, so please replenish or replace the oil in time to avoid any engine fault.</p>
8			<p>When the Brightness Control indicator is enabled, the instrument automatically adjusts its brightness according to the external environment light.</p>

Instrument Display

Optional Info 1

The user can select a message from the menu to be displayed here or on the main interface.

Press ▲ to choose Optional Info 1.

Optional Info 1: TRIP 1, TRIP 2, ODO.

Ambient Temperature

The current external temperature is displayed here.

Celsius °C and Fahrenheit °F can be switched through the menu.

An icing warning will appear when the ambient temperature is below -5°C for a long time, and it means that risks of slippery roads will increase



Coolant Temperature

Coolant temperature is displayed by several bars. The more the number of bars lit up, the higher the coolant temperature. When the last bar turns red, the coolant reaches the dangerous temperature which exceeds 115°C .

WARNING

Too-high temperature may damage the engine.

If the coolant reaches the dangerous temperature, please park the vehicle in line with local laws and regulations and wait for the temperature to drop.

Please replenish the coolant to its proper level after the cooling system has been totally cooled.

Under normal riding conditions, if the coolant reaches the dangerous temperature, please timely contact an authorized CFMOTO after-service center.

Menu

Press ENT to enter the menu, and please refer to the Instrument Menu chapter.





Gear Change Reminder

The user can enable the Gear Change Reminder in the menu. Remind the user to change gear when the engine speed reaches the recommended gear-shifting range.

Fuel remained

Fuel remained is displayed by several bars. The more the number of bars lit up, the more the fuel remained. When the fuel symbol turns yellow, the fuel remained is close to the limit.

When the fuel remained approaches the limit, please arrange the remaining journey as soon as possible and replenish the fuel in time. Insufficient fuel may cause damage to the fuel pump.

Gear display

Current vehicle's gear is displayed here.
The neutral gear is green.



Optional Info 2

The user can select a message from the menu to be displayed here or on the main interface.

The user can select a message from the menu to be displayed here or on the main interface.

Press ▼ to choose Optional Info 2.

Optional Info 2: Mileage, Voltage, Instant Fuel Economy, Riding time 1, Riding time 2, Total Riding Time, Average fuel consumption 1, Average fuel consumption 2, Total average fuel consumption, Average riding speed 1, Average riding speed 2, Total riding speed.

Speed

The current speed per hour is displayed here.

Metric km/h and British mph can be switched through the menu.

Caller Identification

When the instrument is connected to the phone through Bluetooth and receives a call, the incoming call will be displayed in this area. Press the ENT button on the left handlebar to pick up the phone, and press the button on the left handlebar to hang up the phone.

Clock

The current time is displayed here.

Set the current time through the menu.

Switch between 12 hours and 24 hours through the menu.

Bluetooth

Bluetooth is used to connect mobile phones and helmets.

When the user's mobile phone is connected to the motorcycle's instrument through Bluetooth, the area will display the Bluetooth logo, the signal strength and power remained of the mobile phone.

Functions of navigation, music and calling can only be used when the phone is properly connected to the motorcycle.





Side Stand Indicator

When the side stand is used, its indicator light is on. At this time, the motorcycle cannot be started with gear.

Stop Indicator Light

When the stop indicator light is on, the stop switch is turned off and the vehicle is off.

Engine RPM

The unit of engine speed is 1000 revolutions per minute.

In the run-in period, avoid too-high engine speed; Avoid engine speed approaching the red zone at all times as much as possible, which will increase engine life; Avoid high engine speed until the engine is heated up.

TC Indicator

TC indicator function: TC working indicator (TC), TC default indicator (TC!), TC off indicator (TC).

TC working indicator will flash when it is working; TC default indicator will flash when default occurs; TC close indicator will flash when the TC indicator is off.

Instrument Menu

Adjust instrument settings through the Instrument menu to optimize the riding experience.

Press menu button on the left handlebar switch to enter the instrument menu.

WARNING

The menu mode is only allowed when the motorcycle is parked and safe.

The menu button is on the left handlebar switch and is used to operate relevant functions of the instrument.



For Main interface: press it to switch Optional Info 1 and long press it to reset trips.
For the first-level menu, second-level and lower menu: press it to select the prior choice.
For Music: at the main interface, press it to increase the volume and long press it to select the prior song. On the Menu interface, press it to increase the volume and long press it to select the prior song.
When on the phone: press it to increase the volume.

For Main Menu: press it to clean the popup window.
For the first-level menu, second-level and lower menu: Press it to return to the prior menu.
For Calling: press it to hang up the phone.
For projection screen: press it to return to the projection screen interface.
For Music: press it to return to the main interface.

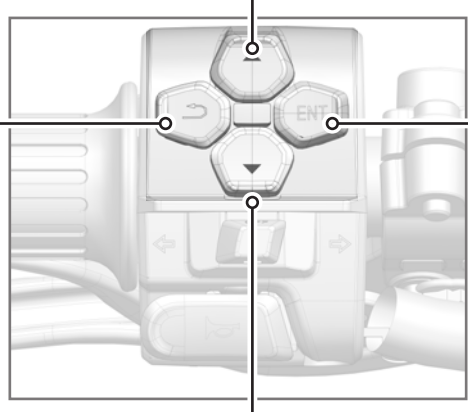

For Main interface: press it to enter the first-level menu, long press it to play the song. (When the bluetooth is connected).
For the first-level menu, second-level and lower menu: press it to enter the next menu or to confirm the choice.
For Calling: press it to answer the call.
For Music: at the main interface, press it to enter the prior menu, and long press it to pause or play.
For music: On the Menu interface, press it to pause or play .

For Main interface: press it to select Optional Info 2.
For the first-level menu, second-level and lower menu: press it to enter the next menu.
When on the phone: press it to decrease the volume.
For Music: at the main interface, press it to decrease the volume, and long press it to select the next song. For music: On the Menu interface, press it to decrease the volume, and long press it to select the next song.

Note: The priority of buttons is calling, music and then others.

Instrument Settings

In the instrument settings, riders can adjust and set the following contents:

Subject Style

Units

Equipment Connection

Optional Info

Brightness Control

TRIP Reset

Overspeed Alarm

Traction Control System

Time Settings

Gear Change Reminder

Language

Reset All



Subject Style

The main interface of the instrument is equipped with multiple sets of subject styles, and you can choose your favorite one in the menu.

Press ENT to enter the Menu interface;

Press \triangle or ∇ to select Settings, and press ENT to enter Settings interface;

Press \triangle or ∇ to select Subject Style, and press ENT to enter;

Press \triangle or ∇ to select your favorite style, and press ENT to confirm your selection.



Units

Change units of speed, time and temperature to suit your reading habits.

Press ENT to enter the Menu interface.

Press \triangle or ∇ to select Settings, and press ENT to enter Settings interface;

Press \triangle or ∇ to select **Units**, and press ENT to enter;

Press \triangle or ∇ to select the unit you need to switch (**Speed/ Time Format /Temperature**), and press ENT to enter;

Press \triangle or ∇ to select the unit, and press ENT to confirm your selection.

km/h mph

24-hour 12-hour

°C °F



Connection

Navigation, telephone calls and music functions can be used after the helmet is connected to the instrument via Bluetooth.

Press ENT to enter the Menu interface;

Press Δ or ∇ to select Settings, and press ENT to enter Settings interface;

Follow these steps to connect your phone Bluetooth:

Press Δ or ∇ to select **Connection**, and press ENT to enter;

Press Δ or ∇ to select **Mobile Device**, and press ENT to enter;

Ensure that the Bluetooth of the mobile phone to be connected is turned on.

Press Δ or ∇ to select your phone, and press ENT to connect;

If the mobile phone was connected, press Δ or ∇ to select the **Mobile Device**, press ENT to enter the interface, and choose the correct Bluetooth ID to connect.

Follow these steps to connect the helmet Bluetooth:

Press Δ or ∇ to select Equipment Connection, and press ENT to enter;

Press Δ or ∇ to select **Helmet 1** or **Helmet 2**, and press ENT to connect;

Ensure that the Bluetooth of the helmet to be connected is turned on.

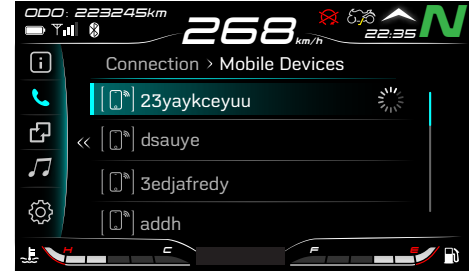

Optional Info

Select one message from Optional Info 1 and Optional Info 2 to display on the main interface.

Press ENT to enter the Menu interface;

Press Δ or ∇ to select Settings, and press ENT to enter the Settings interface;

Press Δ or ∇ to select Optional Info, and press ENT to enter;

Press Δ or ∇ to select Optional Info 1 or Optional Info 2, and press ENT to enter;

Press Δ or ∇ to select the information you want to display on the main interface, and press ENT to confirm your selection.

Optional Info 1: TRIP 1, TRIP 2, ODO.

Optional Info 2: Mileage, Voltage, Instant Fuel Economy, Riding Time 1, Riding Time 2, Total Riding Time, Average Fuel Consumption 1, Average Fuel Consumption 2, Total Average Fuel Consumption, Average Riding Time 1, Average Riding Time 2, Total Average Riding Time.



Brightness Control

Manually adjust the brightness of the instrument, or the instrument automatically adjusts its brightness according to the external environment light.

Press ENT to enter the Menu interface;

Press \triangle or ∇ to select Settings, and press ENT to enter Settings interface;

Press \triangle or ∇ to select **Brightness Control**, and press ENT to enter;

Press ENT to turn on or turn off automatic brightness adjustment;

After turning off the automatic brightness adjustment, the brightness can be adjusted manually.

Press \triangle or ∇ to adjust the brightness, when adjust to the wanted brightness, directly press \curvearrowright to back the interface.

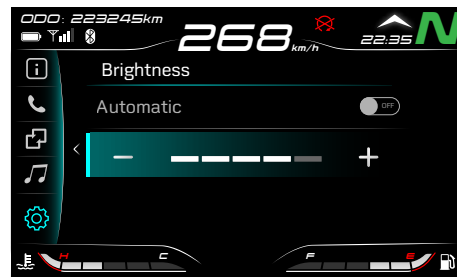

TRIP Reset

Manually reset the trip and clear related data.

Press ENT to enter the Menu interface;

Press Δ or ∇ to select Settings, and press ENT to enter Settings interface;

Press Δ or ∇ to select TRIP Reset, and press ENT to enter;

Press Δ or ∇ to reset **TRIP 1** or **TRIP 2**, and press ENT to reset.



Overspeed Alarm

To set Overspeed Alarm to remind the driver of the speeding when the indicator shows that the actual speed exceeds the set one. The rider should not exceed the maximum speed of current road section of at any time.

DANGER

Speeding increases the risk of losing control of the vehicle, thus leading to accidents. Choose your riding speed based on vehicle load, terrain, visibility, riding conditions, and local laws and regulations, and never exceed the maximum speed.

Press ENT to enter the Menu interface;

Press Δ or ∇ to select Settings, and press ENT to enter Settings interface;

Press Δ or ∇ to mark **Overspeed Alarm**, and press ENT to enter;

Press ENT to turn on or turn off the alarm function;

The alarmed speed can be set after turning on the **Overspeed Alarm**;

Press Δ or ∇ to adjust the alarmed speed (1km/h per gear), when adjust to the wanted alarmed speed, directly press  to back the interface.



Traction Control System

Traction Control System makes the vehicle get the best traction at any driving condition.

Press ENT to enter the Menu interface;

Press \triangle or ∇ to select Settings, and press ENT to enter Settings interface;

Press \triangle or ∇ to mark Traction Control System, and press ENT to enter;

Press ENT to turn on or turn off the alarm function;

To safe drive the vehicle, when the Traction Control System turn on, it can limit the rear wheel power, reduce the danger of sideslip.

Under certain circumstances (eg: Mud, sand, snow or other complicated roads), turn off the Traction Control System temporarily to restore the power of the rear wheel. When out of the difficulty, the Traction Control System should be turn on.



Time Settings

Adjust the time displayed on the main interface.

Press ENT to enter the Menu interface;

Long press Δ or ∇ to select Settings, and press ENT to enter Settings interface;

Press Δ or ∇ to select **Time Settings** and press ENT to enter;

Press Δ or ∇ to select **Hours or Minutes and AM/PM** (when the time unit is set at 12 hours), and press ENT to enter;

Press Δ or ∇ to adjust the time and time period, and press ENT to confirm your selection.

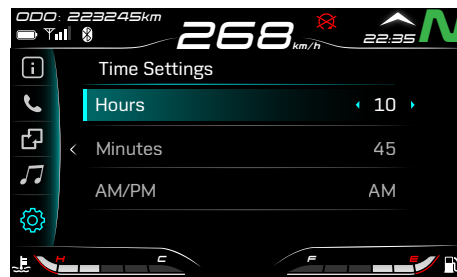

Gear Change Reminder

Shifting at the right RPM can effectively reduce the shifting pauses, protect the clutch and so on. Opening and setting the appropriate Gear Change Reminder can help the driver be more quickly familiar with the vehicle;

The recommended upshifting speed is 6500rpm;

Press ENT to enter the Menu interface;

Press Δ or ∇ to select Settings, and press ENT to enter Settings interface;

Press Δ or ∇ to select the **Gear Change Reminder**, and press ENT to enter;

Press ENT to turn on or turn off the Gear Change Reminder;

Reminded speed can be set after turning on Gear Change Reminder;

Press Δ or ∇ to adjust the upshifting RPM (100rpm for each gear), when adjust to the wanted upshifting RPM, directly press \curvearrowright to back the interface.

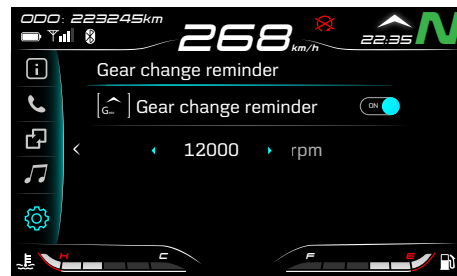

Language

Adjust the instrument's language, switching between Chinese and English to suit your reading habits.

Press ENT to enter the Menu interface;

Press \triangle or ∇ to select Settings, and press ENT to enter Settings interface;

Press \triangle or ∇ to select **Language**, and press ENT to enter;

Press \triangle or ∇ to select **Chinese English** or **Espanol**, and press ENT to confirm.



Reset All

Reset all instrument Settings.

NOTE: This function does not reset ODO or related functions.

Press ENT to enter the Menu interface;

Press \triangle or ∇ key to select Settings, and press ENT to enter Settings interface;

Press \triangle or ∇ to **reset Settings to their factory state**, and press ENT to enter;

Press \triangle or ∇ to select **no/yes**, and press ENT to confirm your selection.



Motorcycle Information

In the Motorcycle Information menu, users can inspect the following contents.

Information

Miles Info

Warning

Service

Version

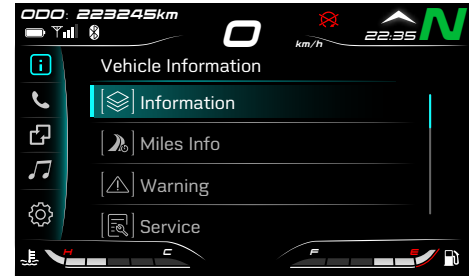

Information

On the Information interface, users can view the coolant temperature, voltage and remained mileage.

Press ENT to enter the Menu interface;

Press Δ or ∇ to select the Vehicle Information, and press ENT to enter the Vehicle Information interface.

Press Δ or ∇ to select **Information**, and press ENT to enter;

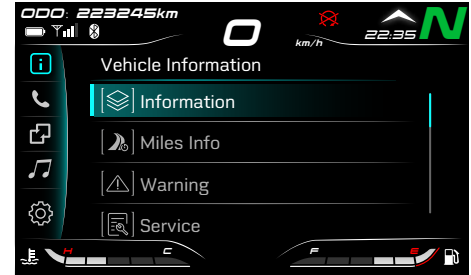

Miles Info

ODO, TRIP 1, TRIP 2, average speed, fuel consumption, driving time can be inspected here.

Press ENT to enter the Menu interface;

Press Δ or ∇ to select the Vehicle Information, and press ENT to enter the Vehicle Information interface.

Press Δ or ∇ to select **Miles Info**, and press ENT to enter;

Press Δ or ∇ to switch ODO-related information or **TRIP 1**- and **TRIP 2**-related information.

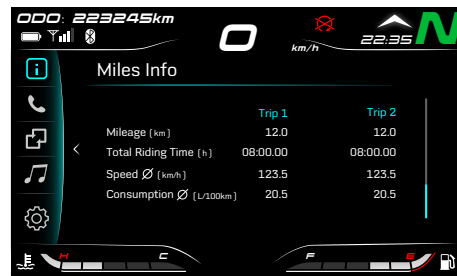
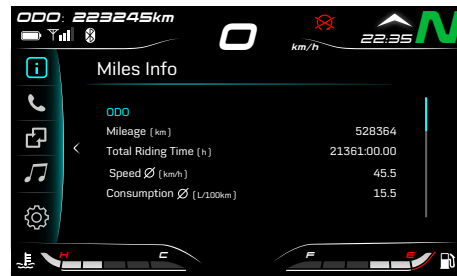

Warning

On the Fault interface, users can view the fault or fault warning when the current vehicle system detects any fault. When the fault occurs, please remove the fault as soon as possible, and contact the after-sales service center authorized by CFMOTO if necessary.

Press ENT to enter the Menu interface;

Press \triangle or ∇ to select the Vehicle Information, and press ENT to enter the Vehicle Information interface.

Press \triangle or ∇ to select **Warning**, and press ENT to enter;



Service

On the Service interface, users can view the service information of the vehicle. When the user reaches the service mileage, the vehicle will remind the user to carry out service.

Press ENT to enter the Menu interface;

Press Δ or ∇ to select the Vehicle Information, and press ENT to enter the Vehicle Information interface.

Press Δ or ∇ to select Remaining Dist, and press ENT to enter;

Reset Service Reminder

On the Service interface, press ENT for 10 seconds, and then a notice for confirmation will pop up.

Confirm your choice and the reset will be finished.

Or you can ask help from an authorized CFMOTO dealership to finish the service and then reset for the new service interval.

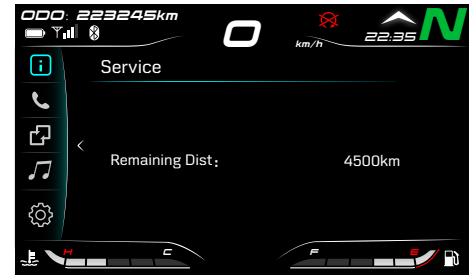
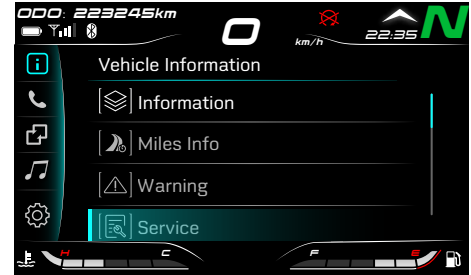

Version

Software and hardware versions of the instrument are displayed here.

Press ENT to enter the Menu interface;

Press \triangle or ∇ to select the Vehicle Information, and press ENT to enter the Vehicle Information interface.

Press \triangle or ∇ to select **Version**, and press ENT to enter;

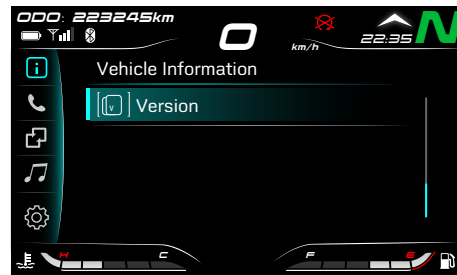

Telephone

In the Telephone menu, users can check the following contents.

Contacts

Recent Calls

NOTE: before using the telephone, the equipment must be correctly connected, and the phone helmet should be connected to the instrument.

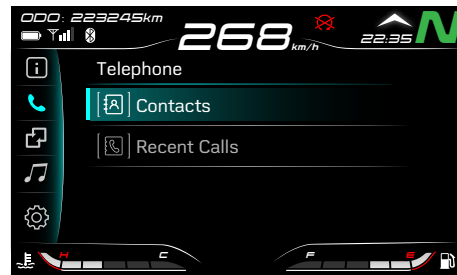

Contacts

On the Contacts interface, users can view the contacts recorded by their Bluetooth-connected mobile phones and dial the numbers.

Press ENT to enter the Menu interface;

Press Δ or ∇ to select Telephone, and press ENT to enter Telephone interface;

Press Δ or ∇ to select **Contacts**, and press ENT to enter;

Press Δ or ∇ to select the number, and press ENT to dial the number.

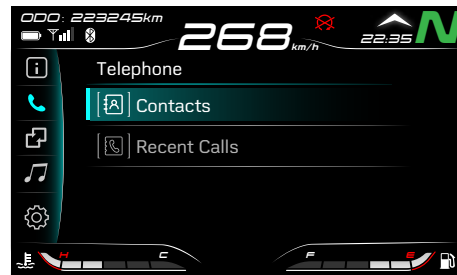

Recent Calls

On the Recent Calls interface, users can view the recent calls recorded by the Bluetooth-connected mobile phone and dial the numbers.

Press ENT to enter the Menu interface;

Press Δ or ∇ to select Telephone, and press ENT to enter the Telephone interface;

Press Δ or ∇ to select **Recent Calls**, and press ENT to enter;

Press Δ or ∇ to select the number in the latest calls, and press ENT to dial the number.

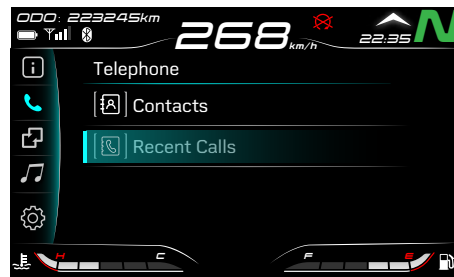

Telephone Interconnect (If equipped)

On the Telephone Interconnect interface, users can via the Easy Connection (the vehicle owner only) or scan the QR code achieving telephone interconnect, the users can use the projection screen function after it is connected.

Open the CFMOTOPLAY app, the vehicle owner will have two options to achieving this function:

1. The Easy Connection
2. Scan the QR code

The vehicle owner can click the option 1: the Easy Connection, enter to the projection interface;

The users could be following the steps to achieving the telephone interconnect function;

Press ENT to enter the menu interface;

Press Δ or ∇ to select the telephone interconnect, press ENT to enter the telephone interconnect.

Open the CFMOTOPLAY app, enter the CFMOTOPLAY app;

The vehicle owner can click the option 2: the users can via scan the QR code to enter the projection interface.

When users close the APP or disconnect the internet, the interface on the instrument will return to the main interface;

When in the projection interface, press the 'return' to return to



the picture (as the second picture shown, if without any operating for 30s, it will return to the main interface automatically), press the 'return' again to return to the Menu. Conversely, press the ENT twice to return to the projection interface.

In the interconnected condition, if the instrument on the menu or at the interface, the navigation can be projected to the interface.

Music

On the Music interface, users can play songs on the phone through Bluetooth, and through the instrument to switch the previous song and the next song, or to pause, and continue, to adjust volume and use other functions.

Press ENT to enter the Menu interface;

Press Δ or ∇ to select the Music and press ENT to enter the Music interface.

Playing songs on your phone;

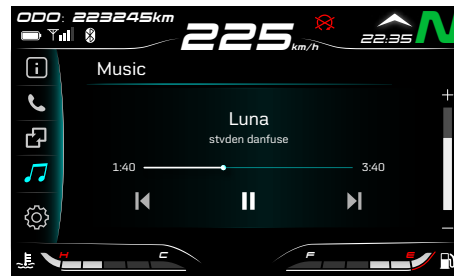

For Music: on the main interface, press it to increase the volume, long press it to switch the previous song.

For Music: on the menu, press it to increase the volume, long press it to switch the previous song.

For Music: on the menu, return to the main interface.

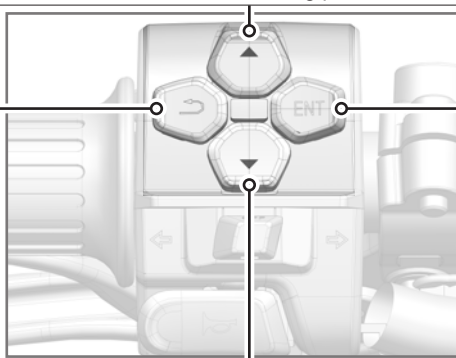

For Music: on the main interface, press it to enter the first-level Menu, and long press to pause or play;

For music: on the Menu interface, press it to pause or play.

For Music: on the main interface, press it to decrease the volume, long press it to switch the next song.

For Music: on the menu, press it to decrease the volume, long press it to switch the next song.

OPERATING YOUR VEHICLE

Break-in Period

The break-in period for this vehicle is 1000km. Maintain the vehicle according to the break-in period requirements.

The following regulations should be observed during a break-in period:

1. Do not run the engine at high speeds immediately when the it is just started. Allow the engine to warm for 2 ~ 3 minutes at idle speed and let the lubricant flow into all the engine' parts.
2. Do not run the engine at high Rpm when the vehicle is in neutral gear.
3. During the break-in period, CFMOTO suggests the top engine speeds as below:

Odometer	Maximum engine RPM
0 km ~ 500 km	4000 r/min
500 km ~ 1000 km	6000 r/min

DANGER

New tires are slippery and can cause loss of control and injury. The specified tire pressure must be guaranteed during a 1000 km break-in period. During the break-in period, avoid sudden or hard braking, sudden acceleration or sharp turns.

Daily Safety Inspection

Inspecting the following items before daily riding will help keep your vehicle safe and reliable. If anything abnormal appears, please refer to the Maintenance and Adjustment section or contact your dealer. Do not operate the vehicle in an abnormal condition, as it may lead to serious damage or accidents.

Item	Content
Engine oil	Inspect the oil level to see whether it is proper.
Rear brake fluid reservoir	Inspect the rear brake fluid level to see whether it is proper.
Rear wheel	Inspect the rear wheel and tire for excessive wear, cracks or cuts, embedded items or other damage. Inspect the rear tire pressure to see whether rear tire pressure is within the standard range.
Rear brake	Inspect the thickness of rear brake pad. Inspect thickness of rear brake disc and inspect for any dirt or damage.
Chain and Sprockets	Inspect the drive chain and sprockets for dirt and wear, and inspect their tension to see whether it is proper.
Front wheel	Inspect the front wheel and tire for excessive wear, cracks or cuts, embedded items or other damage. Inspect the front tire pressure to see whether is within the standard range.
Front brake	Inspect the thickness of front brake pad. Inspect thickness of front brake disc and inspect for any dirt or damage.
Front brake fluid reservoir	Inspect the front brake fluid level to see whether it is proper.

Luggage (if equipped)	Inspect the luggage to see whether it is fastened securely, and make sure the luggage height is in line with local regulations.
Coolant	Inspect the coolant level to see whether it is proper.
Instrument	Inspect the instrument's fault indicators and inspect the fuel to see whether the fuel is enough.
Rear-view mirrors	Inspect the rear view mirrors to see whether they are in an appropriate view angle.
Lights	Inspect all the lights to see whether they all work well and whether the beam height for front lights meets the local regulations.
Operating parts	Inspect the steering, front and rear brakes, throttle and switches to see whether they can be operated smoothly.
Side stand	Inspect the return spring of the side stand for any looseness or damage.
Stop switch	Inspect the stop switch to see whether it works properly.

 DANGER

Inspect the vehicle every time before riding.

The operator must have the related driver's license to ride the vehicle.

Learn the local regulations, and do not ride the vehicle in the areas where motorcycles are not allowed.

Do not start the vehicle in a closed area or an area without a good ventilation system. The exhaust generated during engine operation may cause people to lose consciousness or even cause deaths.

Starting

Sit on the vehicle supported with the side stand up;

Turn on the ignition switch;

Place the gear in Neutral;

Turn the stop switch to position “”;

Press the start button.

CAUTION

Engine running at high RPMs in low temperatures will impact the lifespan of engine. Always warm the engine at a low speed.

Before the instrument self-inspection, do not start the vehicle with the start switch.

The vehicle is equipped with a clutch switch. Pull the clutch lever and shift into a forward gear with the side stand up, the vehicle can be started.

The vehicle is equipped with a side stand switch. When the gear is in Neutral position with the side stand up, the vehicle can be started.

If shifting into a gear with the side stand down, the engine will turn off.

Do not press the start switch for more than five (5) seconds. Please wait for more than 15 seconds to press the start switch again, or it will cause the battery to discharge.

It is recommended that the vehicle should not idle for longer than 30 minutes, for long-time idling will cause battery temperature to be too high and this effects the battery life.

Starting Off

Grip the clutch lever, put the vehicle into gear 1, then slowly release the clutch lever while at the same time gently tighten the throttle.

Shifting, Riding

Grip the clutch lever and release the throttle.

Shift the gearshift lever upward for higher gears as required.

Release the clutch lever and slowly tighten the throttle at the same time to complete the gear shift.

Hold the handlebar at all times with both hands when driving with the throttle tightened.

WARNING

Avoid any abrupt load alterations or strong brake operation, which can cause the vehicle loss of control.

Adjust the speed according to road conditions and situation around you.

When the engine RPM is high, do not shift into lower gears. Release the throttle first and reduce the engine speed.

All adjustments for vehicle operation should be made when vehicle is being parked.

The passenger must be seated properly on the passenger seat with feet on the rear foot pedals, wearing a helmet and with other safety protection, and holding onto the operator or grab the handle.

Comply with the local traffic regulations for minimum passenger age.

Comply with all local traffic regulations, ride preventively and cautiously to detect any danger as early as possible.

When the tires are in a low temperature, their road grip performance is reduced. Be cautious and ride at an average speed until the tires are at their available temperature.

Do not exceed the maximum full load, which includes the motorcycle, driver, passenger and luggage.

 **WARNING**

Luggage sliding will affect the riding performance, inspect the luggage to see whether it is fixed tightly on the vehicle, and to ensure that the width does not exceed 0.15m from the handlebar for both left and right sides.

In the event of an accident, the damage from crashing could be more serious than it looks. Inspect the vehicle completely to make sure it is safe, or take the vehicle to a CFMOTO dealer for inspection.

Improper gear shifting may lead to damage of the gear box.

Tighten the throttle according to the road conditions and climate. Do not shift gears and be cautious to tighten the throttle especially during turnings.

Brake

Release the throttle when applying the brake, and use front and rear wheel brakes for braking at the same time.

Finish braking before turning, and shift to a lower gear according to the speed required.

On a long downhill ride, please leverage the brake force of the engine and shift to lower gears, but do not allow the engine to operate with high RPM. When using engine's brake force, it helps to reduce the braking force required of the brake system, and the brake will not be overheated.

WARNING

Moisture and dirt will impair the brake system. Brake carefully several times to dry out moisture and remove dirt from the brake pads and discs.

If the hand brake lever and foot brake lever feel soft, stop riding until the brake system is fully inspected and the faults eliminated.

Take your foot off the foot brake lever when you are not braking. Long-time braking will cause brake pads overheating and excessive wear, which will affect service life and safety.

When carrying a passenger or luggage, the required braking distance will be increased. Please adjust the brake time according to the vehicle load.

When the ABS is used, you can achieve maximum braking power even on low grip surfaces such as sandy, wet or slippery roads with no risk of locking of the wheels.

Parking

Stop the vehicle with brake;

Shift the gear to Neutral;

Turn off the ignition switch;

Park the vehicle on a firm, level ground;

Use a side stand to support the vehicle;

Turn the handlebar left to the maximum, and lock the steering with the key;

Remove and take away the key.

WARNING

When engine is running, do not leave the vehicle unattended.

Secure the vehicle against use by unauthorized persons.

Lock the steering when leaving the vehicle unattended.

After running the vehicle, its temperature will be very high for some parts. Do not touch any parts such as the exhaust system, cooling system, engine, or brake system.

Do not park the vehicle near materials that are highly flammable or explosive. High temperature parts may ignite the materials.

Improper parking operation may cause vehicle to slip and roll over, which will lead to severe damages.

SAFETY OPERATION

Safe Riding Tips

The following items are applicable for daily motorcycle use and should be carefully observed for safe and effective vehicle operation:

For safety, goggles and a helmet are strongly recommended. You must be aware of traffic regulations for the safe riding. Safe riding gear such as gloves and suitable footwear should also be used for protection.

Wear protective apparel when riding in case of any collision with other vehicles. Without protective apparel, no safety can be ensured. Before changing lanes, look over your shoulder to make sure the way is safe. Do not rely solely on the rear-view mirrors. You must judge distance and speed of other cycles, or accidents may occur.

When climbing up steep slopes, shift to a lower gear to increase the motor's torque output, thus avoiding overloading.

When applying the brakes, apply both the front and rear brakes at the same time. Applying only one brake for sudden braking may cause the motorcycle to skid and lose control.

When going down long downhill slopes, control vehicle speed by releasing the throttle. Use the front and rear brakes for auxiliary braking.

In wet conditions, rely more on the throttle to control vehicle speed and less on the front and rear brakes. The throttle should also be used judiciously to avoid skidding the rear wheel during rapid acceleration or deceleration.

Riding at the proper speed and avoiding unnecessary acceleration are important not only for safety and low fuel consumption, but also for longer vehicle life and quieter operation.

When riding in wet conditions or on loose roadway surfaces, vehicle performance will be reduced. All of your actions should be smooth and flexible under these conditions. Sudden acceleration, braking or turning may cause loss of control.

Practice your operating skills cautiously and slowly in an open area and hold the fuel tank with the knees for better stability. When there is a quick acceleration, shift to a lower gear to obtain the necessary power. Do not downshift at high rpm to avoid damage to the engine. Avoid unnecessary use of fabric tape which may entangle the rider or motorcycle.

Additional Cautions for High Speed Operation

Brakes: Braking is very important, especially during high speed riding and the braking force cannot be too large. Inspect and adjust the brakes to get better performance.

Handling: Looseness of the handling parts may cause loss of control. Inspect the steering to see whether it can turn freely without shaking.

Tires: High speed operation requires the tires to be in good condition. Good-condition tires are crucial for safe riding. Inspect their pressure and the wheel balance.

Fuel: To ensure that there is enough fuel and a smooth supply of fuel for high speed operation.

Oil: To avoid engine failures which could result in loss of control, make sure the oil level is maintained between the upper and lower level lines.

Coolant: To avoid overheating, check and make sure that the coolant level is between the two level lines.

Electrical Equipment: Make sure that the headlights, tail/brake light, turn signals, horn and etc. work properly.

Fasteners: Make sure that all nuts and bolts are tight and that all safety-related parts are in good condition.

DANGER

Do not speed on expressways and obey the relevant laws and regulations. Electric motorcycles are banned on expressways in some parts unless they are approved by traffic authorities and have the relevant skills and protection conditions.

MAINTENANCE

Careful and periodic maintenance will help keep your vehicle in the safest, most reliable condition. Inspection, adjustment, and lubrication of important components are explained in the Periodic Maintenance Chart.

Inspect, clean, lubricate, adjust, and replace parts as necessary. When inspection reveals the need for replacement of certain parts, always use original parts from your dealer.

NOTE

Periodic maintenance and adjustments are critical. If you are not familiar with relative procedures, have a qualified dealer do that for you.

Pay special attention to the oil level during cold weather operation. A rise in oil level can indicate that there are contaminants collecting in the oil sump or crankcase. Change oil immediately if the oil level begins to rise. Monitor the oil level, and if it continues to rise, stop using the vehicle and inspect for reasons or see your dealer.

Improper Use

CFMOTO defines improper use of the vehicle as:

- Often immersed in mud, watery or sandy places.
- Racing or race-style use of high RPM.
- Running at low speed for a long time, and carry heavy load.
- Idle the engine for a long time.
- Short-distance operation in a cold weather.
- For commercial use.

If this vehicle is used in a way that matches any of these definitions, decrease the maintenance intervals by 50%.

Key Points of Lubrication Schedule:

Check all components at the intervals outlined in the Periodic Maintenance Chart. Items not listed in the schedule should be lubricated at the general lubrication interval.

- Change lubricants more often under severe conditions, such as being used in wet or dusty conditions.
- Lubricate before long periods of storage, after pressure washing, or after submerging drive system

Item	Specifications	Method
Engine oil	SAE 10W-40 SJ or higher JASO MA2	Inspect the oil level from the oil view window.
Brake fluid	DOT4	Keep the level between upper and lower lines.

Break-in Periodic Maintenance Chart

Item		Break-in Maintenance Interval (Maintain the item that reaches the interval first)			
		Hour	Month	Km	Notes
Engine					
■	Oil and oil filter	-	-	1000	Replace.
■	Coarse oil filter	-	-	1000	Clean.
	Idle	-	-	1000	Inspect.
■	Coolant	-	-	1000	
	Throttle system	-	-	1000	
Electrical system					
■	Functions of electrical parts	-	-	1000	Inspect.
	Battery	-	-	1000	
	Fuses or circuit breakers	-	-	1000	
Brake					
	Brake discs	-	-	1000	Inspect.
	Brake pads	-	-	1000	
	Brake fluid level	-	-	1000	
■	Brake hoses	-	-	1000	Inspect brake hoses for damage and to see whether they are sealed.
	Brake lever	-	-	1000	Inspect free play.

▲ = The maintenance interval is shortened by 50% if the motorcycle is used badly.

■ = Have an authorized dealer repair involved components and systems.

Item	Break-in Maintenance Interval (Maintain the item that reaches the interval first)				
	Hour	Month	Km	Notes	
Wheels					
	Tire condition	-	-	1000	Inspect.
	Tire pressure	-	-	1000	
Suspension					
■	Rear and front shock absorbers	-	-	1000	Inspect for oil leakage(maintain front forks and the rear shock absorber according to the requirement and purpose).
Cooling system					
	Coolant level	-	-	1000	Inspect.
■	Coolant	-	-	1000	
■	Radiator fan function	-	-	1000	
	Coolant hoses	-	-	1000	
Steering system					
■	Steering bearings	-	-	1000	Inspect

▲ = The maintenance interval is shortened by 50% if the motorcycle is used badly.

■ = Have an authorized dealer repair involved components and systems.

Item		Break-in Maintenance Interval (Maintain the item that reaches the interval first)			
		Hour	Month	Km	Notes
Other parts					
■	Fault control memory	-	-	1000	Read with PDA.
■	Movable parts	-	-	1000	Lubricate, and inspect their flexibility.
■	Bolts and nuts	-	-	1000	Inspect their firmness.
■	Cables	-	-	1000	Inspect them for damage, bending and inspect their setting.

▲ = The maintenance interval is shortened by 50% if the motorcycle is used badly.

■ = Have an authorized dealer repair involved components and systems.

After Break-in Periodic Maintenance Chart

Item	After Break-in Maintenance Interval (Maintain the item that reaches the interval first)				
	Hour	Month	Km	Notes	
Engine					
	Oil and oil filter	-	6M	5000	Replace.
	Coarse oil filter	-	6M	5000	Clean.
■	Clutch	-	-	5000	Inspect and repair or replace if necessary.
	Idle	-	-	5000	Inspect and adjust if necessary.
■	Coolant	-	24M	35000	Replace.
	Throttle	-	-	5000	Inspect and adjust if necessary.
■	Throttle body	-	-	5000	Clean.
▲ ■	Air filter elements	-	-	5000	Clean.
		-	24M	20000	Replace.
■	Spark plug	-	-	5000	Inspect and replace if necessary.
		-	-	10000	Replace.
■	Valve clearance	-	-	40000	Inspect and adjust if necessary.

▲ = The maintenance interval is shortened by 50% if the motorcycle is used badly.

■ = Have an authorized dealer repair involved components and systems.

Item		After Break-in Maintenance Interval (Maintain the item that reaches the interval first)			
		Hour	Month	Km	Notes
Electrical system					
■	Functions of electrical parts	-	12M	10000	Inspect and repair or replace if necessary.
	Battery	-	6M	5000	Inspect and recharge if necessary.
	Fuses or circuit breakers	-	6M	5000	Inspect and replace if necessary.
■	Cables	-	12M	10000	Inspect for any damage and bending when they are being set.
Wheels					
	Wheel condition	-	12M	10000	Inspect and repair or replace if necessary.
	Wheel pressure	-	12M	10000	Inspect and replenish if necessary.
■	Wheel bearings	-	-	10000	Inspect and repair or replace if necessary.

▲ = The maintenance interval is shortened by 50% if the motorcycle is used badly.

■ = Have an authorized dealer repair involved components and systems.

Item		After Break-in Maintenance Interval (Maintain the item that reaches the interval first)			
		Hour	Month	Km	Notes
Brake					
	Front and rear braking systems	-	12M	10000	Inspect and repair or replace if necessary.
	Brake discs	-	12M	10000	
▲	Brake pads	-	12M	10000	
	Brake fluid level	-	12M	10000	Inspect and replenish if necessary.
■	Brake hoses	-	12M	10000	Inspect them to see whether they are damaged and sealed.
	Brake pedals	-	12M	10000	Inspect free play
■	Brake fluid	-	24M	-	Replace.

▲ = The maintenance interval is shortened by 50% if the motorcycle is used badly.

■ = Have an authorized dealer repair involved components and systems.

Item	After Break-in Maintenance Interval (Maintain the item that reaches the interval first)				
	Hour	Month	Km	Notes	
Suspension					
■	Suspension system	-	-	5000	Inspect and repair or replace if necessary.
■	Front and rear shock absorbers	-	12M	10000	Inspect for oil leakage(maintain front forks and rear shock absorber according to the requirement and purpose).
Frame					
	Frame	-	-	30000	Inspect and repair or replace if necessary.
Steering system					
■	Steering bearings	-	12M	10000	Inspect and repair or replace if necessary.

▲ = The maintenance interval is shortened by 50% if the motorcycle is used badly.

■ = Have an authorized dealer repair involved components and systems.

Item	After Break-in Maintenance Interval (Maintain the item that reaches the interval first)				
	Hour	Month	Km	Notes	
Cooling system					
	Coolant level	-	12M	10000	Inspect and replenish if necessary.
■	Radiator fan function	-	12M	10000	Inspect and repair or replace if necessary.
■	Cooling hoses	-	12M	10000	
Sprocket and chain					
▲	Chain lubrication	-	-	600	Inspect immediately after riding in a rainy day.
▲	Chain tightness	-	-	1000	Inspect and adjust if necessary.
▲	Wear of chain, rear sprocket and engine sprocket	-	12M	10000	Inspect and replace if necessary.

▲ = The maintenance interval is shortened by 50% if the motorcycle is used badly.

■ = Have an authorized dealer repair involved components and systems.

Item		After Break-in Maintenance Interval (Maintain the item that reaches the interval first)			
		Hour	Month	Km	Notes
Other parts					
■	Fault control memory	-	12M	10000	Read with PDA.
■	Movable parts	-	12M	10000	Lubricate, and inspect their flexibility.
■	Bolts and nuts	-	12M	10000	Inspect their firmness.
■	Cables	-	12M	5000	Inspect them for damage, bending and inspect their setting.
■	Pipes, ducts, hoses and sleeves	-	12M	10000	Inspect them to see whether they have cracks, are sealed and set corrected.

▲ = The maintenance interval is shortened by 50% if the motorcycle is used badly.

■ = Have an authorized dealer repair involved components and systems.

CLUTCH LEVER FREE-PLAY

Inspect the flexibility of the clutch lever.

Straighten up the handlebar.

Slowly apply the clutch lever until the resistance is evident. The free-play distance of the clutch lever is within the following range.

Free-play: 0.39 in (10 mm)

WARNING

If there is no free play for clutch lever, the clutch cable will strain, clutch of the engine end in the semi linkage state. It will easily cause slip and wear.

Inspect the free-play every time before running the engine.

Set the free-play as stipulated when necessary.

Fine adjustment of clutch lever free-play

Straighten up the handlebar;

Loosen lock nut **1**;

Rotate the adjusting nut **2** for adjustment;

Tighten the lock nut **1**.

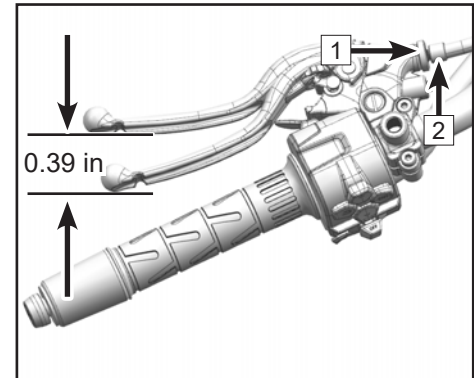

GEARSHIFT LEVER ADJUSTMENT

The gearshift lever is adjustable to suit personal riding habit.

Range: ± 0.2 in (5mm)

Adjust the gearshift lever

Loosen lock nut **1**;

Rotate clockwise the center connecting rod **2** to raise the gearshift lever;

Rotate anti-clockwise the center connecting rod **2** to lower the gearshift lever;

Tighten the lock nut **1**.

TOOL KIT

Tool kit is usually under the cushion and can help maintain and disassemble some parts of the vehicle.

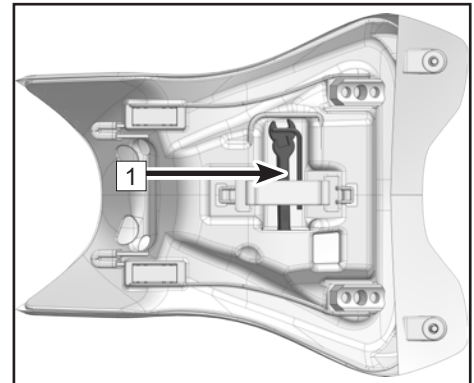
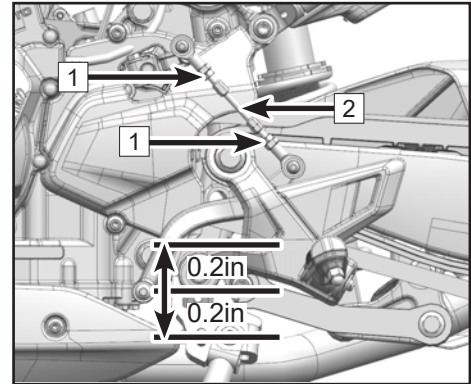

FUEL SYSTEM

Fuel Tank

Avoid spilling fuel to the outside of the fuel tank when filling. If a spill occurs, wipe it off immediately to avoid pollution or causing danger.

Fuel tank volume: 3.7 gal (14 L) ± 0.13 gal (0.5 L)

DANGER

Gasoline is flammable, so the fuel should be filled in a ventilated area. Before refueling, turn off the engine and wait for the engine and muffler to cool. No smoking or any acts that cause sparks are allowed in the fuel filling area or fuel storage area.

Never fill the tank excessively. Avoid the fuel from overflowing onto high-temperature parts. The fuel level should not exceed the tank opening. As temperature rises, fuel can heat and expand, and then may spill over and damage motorcycle parts.

Fuel is toxic and harmful to health. Avoid touching the skin, eyes and clothes. Do not inhale fuel vapor.

If the fuel touches the skin, wash the skin with plenty of clean water.

If the fuel touches the eyes, wash eyes immediately with clean water and see a doctor immediately.

If the fuel touches the clothes, change the clothes immediately.

If the fuel is swallowed by mistake, see a doctor immediately.

After maintenance or other disassembling behaviors of parts of the fuel system, please contact your dealer for complete inspection to avoid fuel leaks or other dangers.

Dispose of the fuel properly to avoid damage to the environment.

Fuel Requirements

This motorcycle is recommended to use only unleaded gasoline(95# or higher).

CAUTION

Do not use leaded gasoline, as it will destroy the catalytic converter. (For further understanding, please consult related materials about the catalytic converter)

Be sure to use fresh gasoline. Gasoline oxidation will result in loss of octane and volatile compounds. It also produces colloidal and lacquer deposits which could damage the fuel system.

Octane Rating (RON)

'RON' is a technical term commonly used to describe the octane rating of gasoline. The higher the number of RON, the greater the resistance to knocking and detonation. Always use unleaded gasoline with an octane rating equal to 95# or higher.

CAUTION

If the engine has a knocking cylinder or detonation, use a unleaded gasoline of higher quality or higher RON.

ENGINE ASSY

For the engine, transmission, clutch and other parts to work properly, make sure that the oil level is between the upper and lower lines from the oil view window, and check and replace the oil according to the Periodic Maintenance Chart. Long-time lubrication will not only produce dirt and metallic impurities, but also consume itself.

DANGER

Riding the motorcycle with insufficient, deteriorated or highly contaminated oil will cause accelerated wear and may result in engine or transmission's damage, which could cause an accident and/or personal injury.

Oil Level Inspection

Make sure the vehicle is turned off.

If the running was operated prior to turning off, please wait for 2 to 3 minutes for the oil to settle.

Support the vehicle vertically on a level surface, and then view the oil level inspection window:

If the oil level is at area A, drain out the oil until the level is within area B;

If the oil level is at area B, it is at the proper level;

If the oil level is at area C, or no oil level can be viewed, fill the engine with the recommended oil until the level is within area B.



Oil and Oil Filter Replacement

Park the vehicle by on the level ground;
Idle the engine for several minutes to warm up the engine, then turn off the engine;

WARNING

Warming up the engine for a long period may lead to high temperature of the engine and oil. Please wear suitable protective clothing and gloves when changing oil. In the event of scalding, wash the scaled area immediately with running water for more than 10 minutes until feeling no pain and see a doctor.

Remove the bolt ;

Take out the left side protective panel ;

Place an oil basin under the location where drain out the oil;

Remove the magnetic oil drain bolt and washer ;

Drain out completely the used oil;

WARNING

Oil is a toxic substance, so the used oil should be disposed of properly.

Replace with a new oil filter ;

Clean the oil drain bolt and the area around the oil drain hole;

Place a new washer on the oil drain bolt, and then remount the oil drain bolt and washer.

Tightening torque: 18.4 ft-lb (25 N•m)

Reinstall the left side protective panel and mounting bolts.

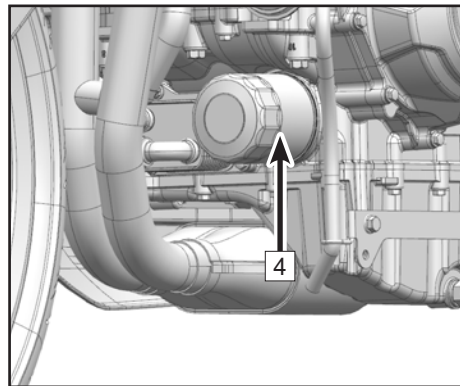
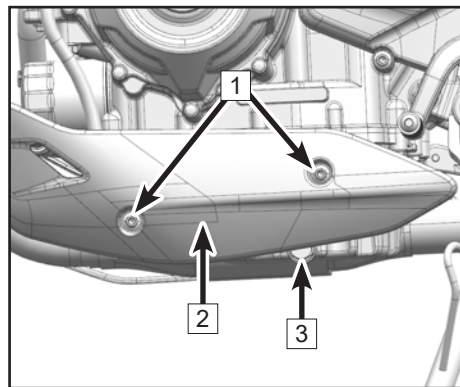

Remove the oil filler screw plug **3**;

Fill with 2.64 qt (2.5 L) oil of SAE 10W/40 SJ or higher, JASOMA2;

Remount the oil filler screw plug;

Idle the engine for several minutes, allowing the oil to flow into the oil filter;

Turn off the engine;

Inspect the oil level and adjust it according to the real level.

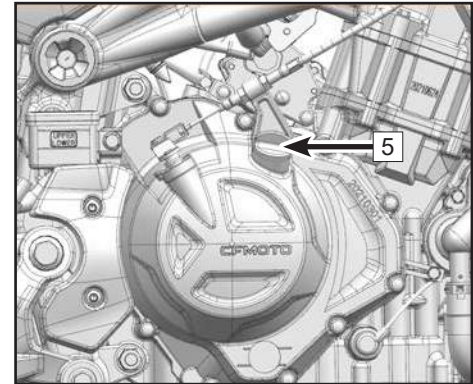

Oil Capacity

Replace oil filter: 2.64 qt (2.5 L).

CFMOTO recommends the kind of oil with APISH or higher, with JASO-MA2 as the primary choice and JASO-MA as an acceptable alternative.

Although 10W-40 oil is the recommended oil for most conditions, the oil viscosity may need to be changed to accommodate atmospheric conditions in your riding area. Please choose oil viscosity according to the chart.

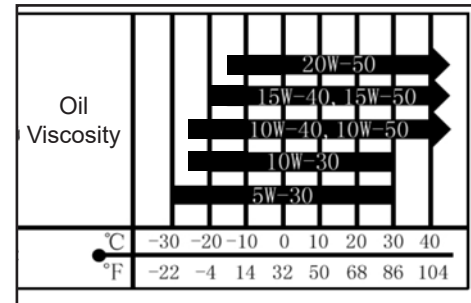

Spark Plug

The spark plug should be replaced in accordance with the Periodic Maintenance Chart.

Its disassembly should only be performed by an authorized dealer.

Spark plug type: BN8RTI.

Spark plug clearance 1 : 0.03 in ~ 0.04 in (0.8 mm ~ 1 mm)

Tightening torque: 8.8 ft-lb (12N•m) ~ 11.1 ft-lb (15 N•m)

Idling

The idling speed of this vehicle has been adjusted at the factory and cannot be adjusted by users, otherwise its performance will be affected. When parts affecting idling speed need to be replaced, contact your dealer for replacement and recalibrate the ECU with PDA.

⚠ DANGER

Improper adjustment of idling may cause serious consequences.

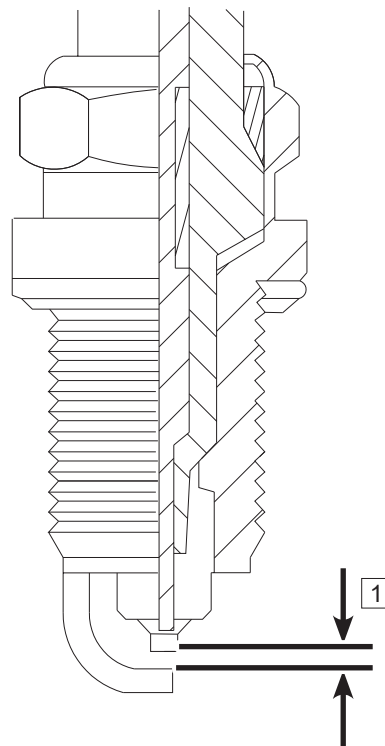

AIR INTAKE AND EXHAUST SYSTEM

Exhaust Detecting System

Exhaust detecting system depends on two oxygen sensors **1** mounted on exhaust pipes, and they can detect the air & fuel combustion degree by measuring oxygen density and transferring it as an electrical signal to the ECU. If the ECU thinks that combustion is not thorough, it will adjust fuel injection in accordance with signals from the Throttle Position Sensor and Intake Air Temperature sensors. By this way, the ratio of air to fuel can be optimized for thorough combustion.

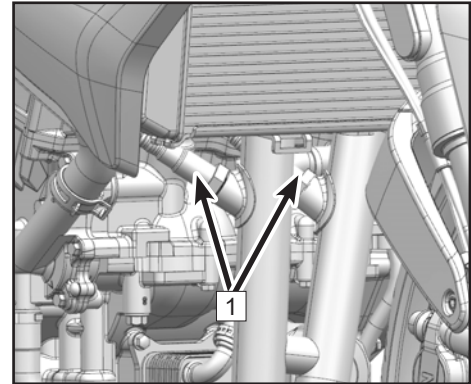

Air Intake Valve

An air intake valve is a valve which allows fresh air to flow only from the air filter into the engine. Any air that passes through the air intake valve is prevented from returning. Have a dealer inspect the air intake valves in accordance with the Periodic Maintenance Chart. Also, have the air intake valves inspected whenever stable idling cannot be performed stably, engine power is greatly reduced, or there are abnormal engine noises.

Air intake valve removal and inspection should only be performed by an authorized CFMOTO dealer.

Valve Clearance

The valves and valve seats will wear during operation, thus the need for adjustment after being used for a period of time.

WARNING

When valves and valve seat tappets are worn during use, and if adjustment of the valve clearance is not performed, it will eventually result in no clearance or cause the valves remaining partly open, which reduces performance, creates valve noise, and can cause serious engine damage. Valve clearance for each valve should be inspected and adjusted in accordance with the Periodic Maintenance Chart. Inspection and adjustment should be performed by a CFMOTO dealer.

Air Filter

A clogged air filter restricts air flow, increases fuel consumption, reduces engine power, and causes spark plug fouling. The air filter element must be cleaned in accordance with the periodic Maintenance Chart. When driving in dusty, rainy, or muddy conditions, the air filter element should be serviced more frequently than the recommended interval in the periodic Maintenance Chart. Due to the vehicle's design, air filter service should be only performed by an authorized dealer.

Indicator hose **1** alerts to excessive dirt, residual oil or water in the air filter.

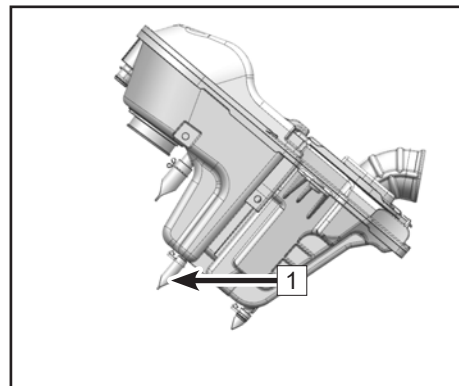

CAUTION

Oil on tires and plastic or other parts will cause damage.

If engine intakes with the unfiltered air, will have a negative effect on the service life of the engine.

Never start to use the vehicle without an air filter.

Throttle Body

The stop screws on the throttle body have been set precisely and can not be adjusted. Inspect the vehicle to see whether its idling is stable, and if the idling is not stable, please ask CFMOTO to assign professional technicians to deal with this problem.

COOLING SYSTEM

Radiator and Cooling Fan

Inspect the radiator fins for deformation and obstruction by mud, and clean off any obstruction with clean water.

WARNING

When the fan is working, prevent your hands and clothing from getting inside the fan to avoid any injury.

Using high-pressure water to clean the vehicle could damage the radiator fins and reduce the radiator's effectiveness.

Mounting unauthorized accessories in front of the radiator or behind the cooling fan may obstruct or change the radiator airflow, and can lead to overheating and damage.

If the radiator pipe is obstructed more than 20% by irremovable obstructions or irreparable deformed fins, then replace it with a new radiator.

Radiator Hoses

Inspect the radiator hoses for leaks, cracks, aging, rust, corrosion and connections for leaks or looseness daily before riding the motorcycle. Inspect the vehicle in accordance with the Periodic Maintenance Chart.

Coolant

Coolant absorbs heat from the engine and transfers it to the air by the radiator. If the coolant level is too low, the engine will overheat and may suffer from severe damages. Inspect the coolant level daily before riding the motorcycle and perform maintenance in accordance with the Periodic Maintenance Chart. Replenish the coolant if its level is too low.

To protect the cooling system (engine and radiator are made of aluminum) from rust and corrosion, the use of anti-corrosion and anti-rust chemicals in the coolant is essential. If the coolant has already these chemicals, there is no need to add them separately.

DANGER

Coolant is toxic and harmful to health.

Do not allow the coolant to touch skin, eyes or clothing.

If coolant is swallowed, see a doctor immediately.

If coolant touches the skin, flush the skin with plenty of clean water immediately.

If coolant touches the eyes, flush the eyes with plenty of clean water and see a doctor immediately.

If coolant splashes on clothes, change the clothes and wash them immediately.

Any corrosion or rust remains from the engine and radiator should be disposed of by special instructions, because the chemicals inside are harmful to the human body.

⚠ CAUTION

Do not add tap water to the coolant system, for it will cause deposit inside the cooling system. When the temperature is below 0°C, ice will occur and severely affect the coolant system.

Available bottled antifreeze in the market contains anti-corrosion and anti-rust chemicals. When it is diluted, it loses its anti-corrosion and anti-rust function. Keep the diluted concentration of antifreeze the same as the instructions from the manufacturer.

When replenishing the coolant which color is green and contains ethylene glycol. When the environment temperature is below -31°F (-35°C), please ensure the coolant has a freezing point below -31°F (-35°C).

Coolant Level Inspection

Support the vehicle vertically on a level surface;

Inspect the coolant level in the reservoir **1**;

If the level is at area 'A': Drain out the redundant coolant until it is at area 'B';

If it is at area 'B': The coolant is at the proper level;

If the level is at area 'C' or cannot be seen: Replenish it with the same coolant until the level is at area 'B'.

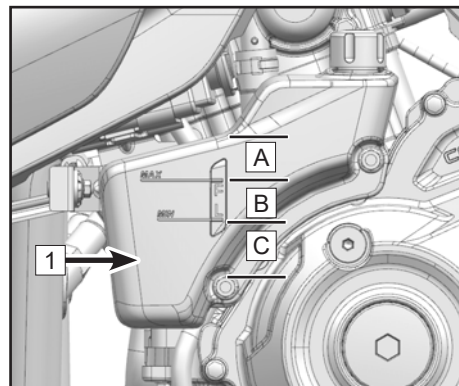

⚠ WARNING

When the vehicle is running, the coolant will have a very high temperature and stay in a state of compression.

Before the engine or cooling system has cooled down completely, do not open the radiator, radiator hoses, reservoir or other cooling-related parts.

In the event of scalding, wash the scalded area immediately with running water for more than 10 minutes until the pain can not be felt and see a doctor.

Coolant Replenishment

Open the reservoir cover and replenish coolant to area B.

CAUTION

If coolant needs to be replenished frequently, or the reservoir is completely dry, there is probably a leak in the system. Have the cooling system inspected by an authorized dealer.

Only recommend the original CFMOTO coolant. Contact your dealer for replacing coolant. Mixing different coolant may lead to engine damage.

TIRES AND CHAINS

This vehicle only uses tubeless tires, rims and inflating valves. Only use the recommended standard tires, rims and inflating valves. Do not mount inner tube tires on tubeless rims. Improper mounting of tires may cause air leakage. Do not mount an inner tube inside a tubeless tire.

Tire Specifications

Tire specifications	Front wheel	110/70 R17 M/C 54H
	Rear wheel	150/60 R17 M/C 66H
Tire pressure	Front wheel	32.6 psi (225 kPa)
	Rear wheel	35.5 psi (245 kPa)
Minimum tread depth	Front wheel	0.03 in ~ 0.04 in (0.8 mm ~ 1 mm)
	Rear wheel	0.03 in ~ 0.04 in (0.8 mm ~ 1 mm)

Improper tire pressure or exceeding the tire load limit may affect the vehicle handling and performance, causing a loss of control.

Make periodic inspections on the tire pressure by a tire pressure gauge and adjust tire pressure accordingly.

Too-low tire pressure may cause the tire improper wear or overheating.

Proper tire pressure offers the best comfort and the longest service life.

NOTE:

Inspect the tire pressure when the tires are cold.

Tire pressure is affected by the change of environment temperature and altitude. If the environment temperature and altitude have a big change during riding, tire pressure should be adjusted and inspected accordingly.

Most countries have their own regulations of minimum tread depth. Please follow local regulations. When mounting new rims or tires, always inspect the wheel balance of the tires.

⚠ CAUTION

In order to ensure safe and stable operation, please only use the tire and pressure recommended. If the tire is punctured and repaired, please do not ride the vehicle at over 100km/h until 24hours after, and the speed cannot exceed 130 km/h at any other time.

The front and rear tires should come from the same manufacturer with the same tread pattern.

New tires can be slippery and may cause a loss of control and injury. Please ride the vehicle in proper ways and use different tilt angles to have the tires create friction with the ground over the entire surface. Normal friction surface will be formed after a 160km break-in period. Avoid sudden braking, heavy acceleration, and high-speed sharp turns during the break-in period.

Tire Payload

The maximum recommended payload is: 330.7 lb. (150 kg), including driver, luggage/cargo and accessories.

Tire Friction

When tire tread wears too severely and the tire cannot be used, the tire becomes more susceptible to punctures and failures. An accepted estimate is that 90% of all tire failures occur during the last 10% of tire service life, so it is unsafe to continue to use bald tires. In accordance with the Periodic Maintenance Chart, measure the depth of the tread with a depth gauge, and replace any tire that has been worn down to the minimum allowable tread depth.

Visually inspect the tire tread for cracks and cuts, and replace it with a new tire if it is severely damaged. For example, if partial expansion appears on the tire, it means the tire is broken.

Remove any embedded stones or other foreign particles from the tread.

CAUTION

When the environment temperature is below 14°F (-10°C), it is recommended to place the vehicle indoors if required to be stored for a long time.

Do not use side stand to park the vehicle for long time in winter. Use the center stand (if equipped) or rear-wheel stand to park the vehicle, to let the tires be free of the wheel weight.

Do not allow the tires to sink into snow or ice for a long time when parking the vehicle in winter.

When parking the vehicle for a long time outside in winter, it is recommended to put objects that can preserve the heat such as branches, paper or sand under the tires.

Drive Chain Inspection

The looseness and lubrication of the drive chain must be inspected daily before riding and safety cautions in the Periodic Maintenance Chart must be observed to prevent excessive wear. If the chain becomes badly worn or maladjusted, it will cause the chain to be too loose or too tight.

If the chain is too tight, it will accelerate the wear to the chain, sprocket, rear sprocket and rear rim. Some parts may crack or break when the vehicle is overload.

If the chain is too loose, the chain may fall off from the sprocket or rear sprocket, which may cause locking of the rear wheel or damages to engine.

The service life of the drive chain largely depends on the maintenance.

Chain dirt inspection

Inspect periodically or inspect the chain for dirt after driving in severe conditions.

If the chain is extremely dirty, flush any large dirt particles with a soft flow of water. Clean any residual dirt and residual lubricant with a proper chain cleaner.

Spray the chain with a proper chain lubricant after the chain is dry.

WARNING

When spraying chain lubricant, do not splash the lubricant onto other parts. Lubricant on the tires will decrease the tire grip, and lubricant on the brake discs will decrease the brake performance. Clean these components with a proper cleaner if the over-spray occurs.

Chain tension inspection

Shift the gear into Neutral;

Park with the side stand;

Push up the chain to inspect its tension;

If the chain tension is not in line with relevant specifications, then adjust it to the standard.

Standard value: 0.98 in ~ 1.38 in (25 mm ~ 35 mm)

NOTE:

The wear of the chain is not always uniform, and the tension should be repeatedly measured by rotating the rear wheel several times in different positions.



Drive Chain Tension Adjustment

Loosen the rear wheel shaft nut **1**;

Loosen the left and right locking nuts **2**;

Screw the left and right adjusting nuts **3** to adjust the chain tension, ensuring the alignment marks on the left and right adjusting block are the same with the reference mark position;

Tighten the left and right locking nuts;

Tighten the rear wheel shaft nut (77.4 ft-lb ~ 81.1 ft-lb)
(105N•m~110N•m).



116

Wear inspection

Shift the gear into Neutral;

Support the vehicle with the side stand.

Apply chain tensioning or hanging a 22 lb (10 kg) object on the chain.

Measure the elongated length between 20 links;

If the measured length exceeds the standard limit, replace the chain with a new one;

Standard limit: 12.6 in (320.7 mm)

DANGER

For your safety, please use the standard chain. When the chain is elongated, never cut the chain and use it again. Have it replaced by an authorized CFMOTO dealer.

Inspect the rear sprocket and engine sprocket tooth surface for any kind of wear.

If the engine sprocket or rear sprocket is worn, then replace the whole set of the transmission.

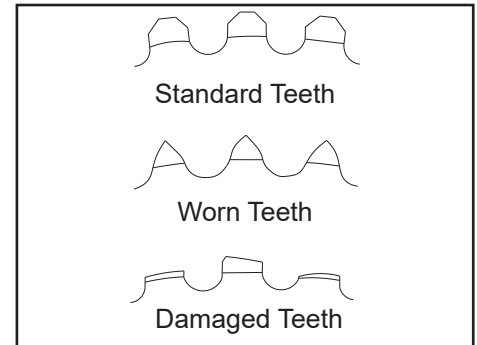
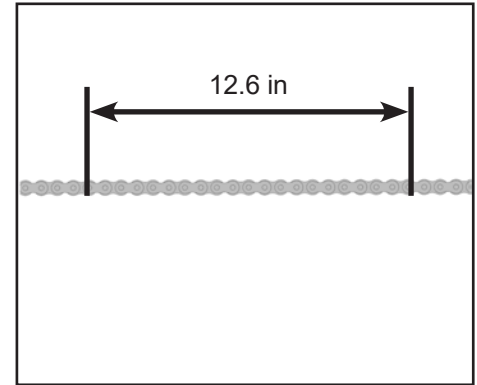

BRAKE SYSTEM

In order to guarantee excellent performance of your vehicle and personal safety, please inspect and maintain the vehicle according to the Periodic Maintenance Chart. Make sure all the parts of the brake system are in a good state. If any damage occurs to the brake system, please stop riding and have your vehicle inspected and maintained by an authorized dealer.

Front Brake Lever Inspection

Park the vehicle with the side stand on level ground;
Grip lightly the front brake lever and inspect its free travel.

Free travel: 0.12 in ~ 0.24 in (3 mm ~ 6 mm)

Inspect the front brake lever for any cracks or abnormal noise;
If these problems occur, replace the front lever with a new one.

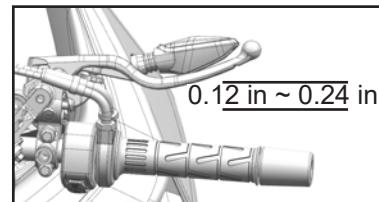

Rear Brake Pedal Inspection

Park the vehicle with the side stand on level ground;
Lightly grip the rear brake pedal and inspect its free travel.

Free travel: 0.39in (10mm).

Inspect the rear brake pedal for any cracks or abnormal noise;
If these problems occur, replace the rear lever with a new one.

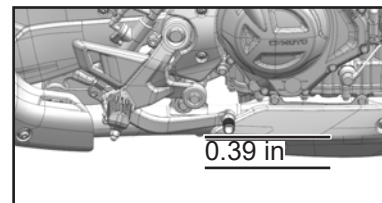

⚠ WARNING

If the brake levers and pedals feel soft, there may be air or lack of fluid in a brake fluid hose. If the vehicle has this dangerous condition, do not ride the vehicle. Have the brake system inspected immediately by an authorized CFMOTO dealer.

Brake Fluid Level Inspection

Support the vehicle vertically on level ground, and confirm the brake fluid reservoirs are level;

Inspect the front and rear brake reservoir fluid levels;

If the brake fluid level is at area 'A': Drain out the redundant fluid until it is at area 'B';

If the brake fluid level is at area 'B': The level is proper;

If the brake fluid level is at area 'C' or cannot be seen: Replenish it with the same brake fluid until the level is at area 'B'.

WARNING

If the brake fluid level drops to area 'C' frequently, the brake system is leaking, not sealed, or is damaged. Have the brake system inspected immediately by an authorized CFMOTO dealer.

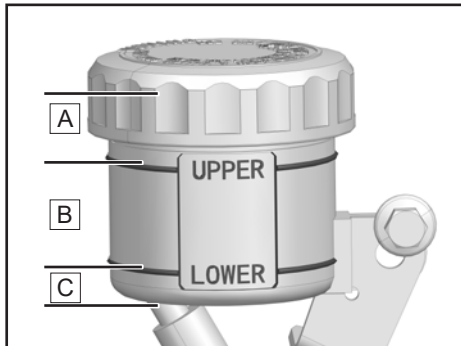

Front brake fluid reservoir

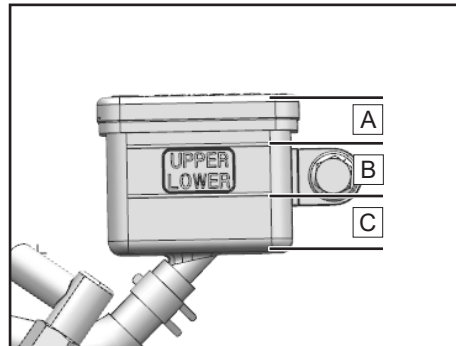

Rear brake fluid reservoir

Brake Fluid Replenishment

WARNING

Brake fluid can irritate the skin.

Keep brake fluid out of the reach of children.

Keep brake fluid away from skin, eyes or clothing. Wear protective clothing and goggles when operating the vehicle.

If brake fluid is swallowed, see a doctor immediately.

If brake fluid touches the skin, wash the skin with plenty of clean water.

If brake fluid touches the eyes, wash eyes immediately with clean water and see a doctor immediately.

If brake fluid spills onto your clothing, change the clothing and wash it immediately.

WARNING

Brake fluid used for a long time will reduce braking efficiency. Please change the brake fluid according to the Periodical Maintenance Chart. Only use the same type DOT4 brake fluid as marked on the fluid reservoir. The mixing of different brake fluids may cause brake system damage or failure, so it is recommended to always use the original CFMOTO brake fluid. If you cannot make sure the original brand, please contact your authorized CFMOTO dealer for brake fluid maintenance.

NOTE

When the brake fluid level goes down, it causes negative pressure inside the fluid reservoir, which may lead the reservoir gasket to sag. Remove the reservoir cap to release the pressure, adjust the reservoir gasket and then remount the gasket and cap.

Front brake fluid reservoir

Remove screws **1**; Remove the bracket **2**;

Remove the cover and reservoir gasket **3**;

Replenish brake fluid to area 'B';

Remount the cover and reservoir gasket;

Mount the bracket **2** and screw **1**.

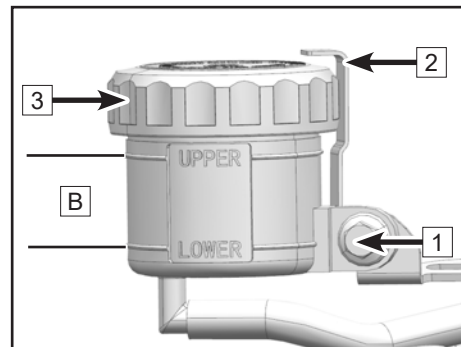

Rear brake fluid reservoir

Remove screws **1**;

Remove the cover and reservoir gasket **2** ;

Replenish brake fluid to area 'B';

Remount the cover and reservoir gasket;

Mount the screws **1** .

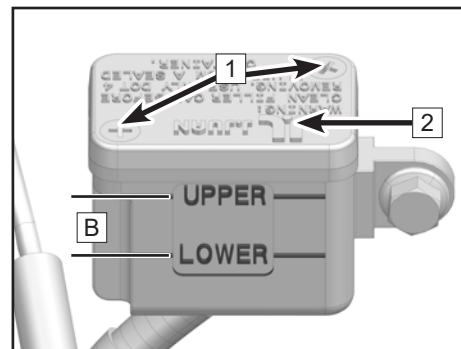

Brake Disc Inspection

Inspect brake discs periodically for any damage, out of shape, cracks or wear. Damaged brake discs may cause braking failure. Worn-out brake discs will decrease braking performance. If brake discs are damaged or exceed the wear limit, contact an authorized dealer to replace them with new ones immediately.

Inspect the thickness of front and rear brake discs in several positions.

Front and rear brake discs wear limit: 0.16 in (4 mm).

Brake Caliper Inspection

Inspect the brake calipers before riding. Inspect the minimum thickness of brake pads periodically. If the brake pads are too thin, their brackets will rub the brake discs, which will severely reduce brake effect and damage the brake pads.

Inspect the minimum thickness of brake pads on all brake calipers.

Brake pad minimum thickness: 0.05 in (1.3 mm).

If the brake pad thickness is less than the minimum limit, or the brake pads are damaged, please contact an authorized dealer immediately to replace the pads in pairs.

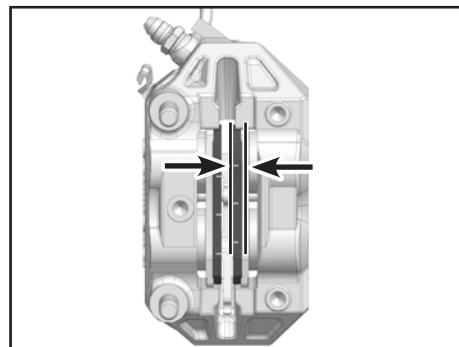
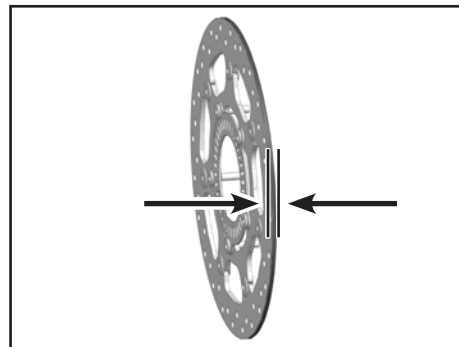

Anti-lock Braking System (ABS)

ABS is a safety system that prevents locking of the wheels when riding in a straight line or a curve without the influence of lateral forces.

With the assistance of ABS, when riding on gritty, water-logging, sliding or other low-adhesive force roads, the vehicle can use its full brake force and will face no risk of wheel locking.

DANGER

Driving assistance can only prevent motorcycle from rollovers within the physical limits. In extreme driving conditions, such as high baggage loading center of gravity, changeable road conditions, steep slopes and full-speed braking without releasing the brake, motorcycle rollovers may occur.

ABS works with two independent brake circuits (front and rear brakes). When the brake electronics control unit detects a locking tendency in a wheel, ABS begins to work by adjusting the brake pressure. The adjusting process can be felt through as a slight bouncing of the front or rear brake pedals.

When turning on the ignition switch, the ABS indicator must be on, and then be off after the starting. If the ABS indicator is still on after the starting or lights up again during the riding, the ABS must have some fault. If a fault occurs, ABS cannot work, and the wheels may be locked during braking. The braking system itself is still working, and only the ABS adjustment system itself is failing.

SHOCK ABSORBER

Shock Absorber Inspection

Holding the handlebar and front brake, compress the front fork for several times to inspect it to see whether its working is smooth;

Visually inspect the front shock absorbers for oil leaks and front fork for scratches or friction noise;

After riding, inspect the front fork to see whether it has mud, dirt or debris, and if so, clean them, or they will lead to oil seal damage and shock absorber oil leak;

Press down the seat several times to inspect it to see whether the rear shock absorber works smoothly;

Inspect the rear shock absorber for oil leak;

If you have any doubt about the front or rear shock absorber performance, please contact an authorized CFMOTO dealer.

Rear Shock Absorber Adjustment

The shock absorber has been adjusted at the factory to the best position which is suitable for most situations.

Contact your dealer to adjust the spring preload. Do not adjust it by yourself.

DANGER

This part contains high-pressure nitrogen, incorrect operation may cause explosion;

Read relevant instructions;

Do not put it into the fire, hole it or open it.

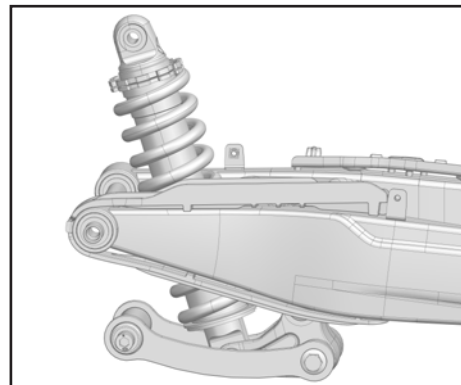

ELECTRICAL SYSTEM AND LIGHT SIGNALS

Battery

It is equipped with lead-acid battery for starting. When the vehicle is not in use for a long time (≥ 2 months), the battery needs to be removed for storage. However, for optimal battery life, you must properly charge the battery to provide enough power for the starter motor. When the vehicle is in frequent use, the vehicle charging system automatically charges the battery. If the vehicle is used only occasionally or for a short period of time, the battery may be low in power.

CAUTION

To avoid battery damage and power loss, do not idle the vehicle for more than 30 minutes. Otherwise, the vehicle cannot be started.

Batteries can also self-discharge which speed depends on battery type and environment temperature. When environment temperature rises for example, the speed could increase by a factor of 1 for every 15°C temperature rise.

Battery sulphation

A common battery failure is sulphation. When the battery is short of power for a long time, electrolyte can be sulphated. Sulphation is an abnormal product produced by chemical reaction in battery. If the battery sulphation occurs, the battery discharging can cause the battery plate permanent damage, and cause the battery to be impossible to be charged. When such a fault occurs, the only way is to replace the battery with a new one.

Battery maintenance

Always keep the battery fully charged, or it may damage the battery.

If the vehicle is driven infrequently, inspect the battery voltage weekly with a voltmeter. If it drops to below 12.8 volts, the battery should be charged(contact your dealer for inspection). If you will not use the vehicle

for longer than 2 weeks, it is a must to charge the battery with a charger. Do not use an automotive quick-charger that may overheat the battery and damage it.

Clean the battery case with a soft brush dipped in a mixture of baking soda and water.

Use a wire brush to remove the corrosion of positive and negative lug plates and positive and negative anodes;

Maintenance-low batteries require special chargers (constant low voltage/ampere). Using traditional battery chargers will reduce battery life.

If the vehicle is not in use for one month or longer, please remove the battery and place it in a dry and cool place. Before remounting, fully charge the battery.

The battery must be removed from the vehicle when it is being charged.

Battery charger

Contact your dealer for battery charger's specifications.

Battery charging

Remove the battery from the vehicle.

Connect the charger wire, and ensure that the charging current is $1/10$ A of the battery capacity, for example: for the capacity of 10 Ah battery, its charging current should be 1 ampere;

Ensure that the battery is fully charged before mounting.

 **WARNING**

Do not remove the battery's sealing strip, or the battery will be damaged. Do not mount an ordinary battery in this motorcycle, or the electrical system will not work properly. When removing the battery, firstly disassemble the negative pole, and then the positive pole. During mounting, the connection sequence of positive and negative poles is opposite to that of disassembly.

When removing the battery, firstly disassemble the negative pole, and then the positive pole. During mounting, the connection sequence of positive and negative poles is opposite to that of disassembly.

NOTE:

When charging a maintenance-free battery, always follow the instructions in this manual.

Battery Removal

Place the vehicle on flat ground and park it;

Completely turn off the engine and power supply of the vehicle;

Insert the key into the cushion lock;

Remove cushion **1**;

Remove the black negative wire (-);

Remove the red positive pole wire (+);

Remove the battery pull belt **2**;

Remove the battery.

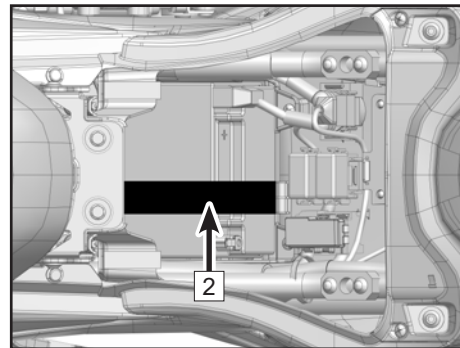
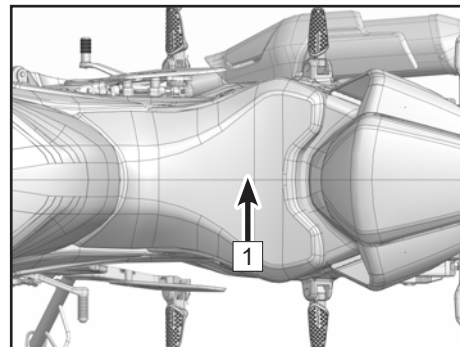

Battery Mounting

Park the vehicle on flat ground;

Ensure that the vehicle's key is in the closed position;

Put in the battery;

Mount battery belt;

Mount the red positive pole wire (+);

Mount the black negative wire (-);

Remount the dust cover and seat.

WARNING

Avoid direct touching with the skin, eyes and clothing. Always protect eyes when working near the battery. Keep the battery out of reach of children. Keep the battery away from sparks, open flames, cigarettes, or other ignition points. When using or charging batteries in a confined space, ventilate the area.

Battery acid detoxification treatment:

External: Rinse the touched area with clean water.

Internal: See a doctor immediately.

Eyes: Rinse the eyes with clean water for 15 minutes and see a doctor immediately.

CAUTION

Improper disassembly and assembly of positive and negative wires may lead to a short circuit between the battery and the vehicle body.

Lights

Headlight and foglight are adjustable. Rotate the light adjusting knob **1** to adjust light.

CAUTION

Adjustment of high/low beams should be in accordance with local regulations. The standard is based on the light emitted when front and rear wheels touch down the ground and the rider sits on the vehicle.

All the lights are LED lights. Have your dealer replace the entire assembly if an LED is damaged or has failed.

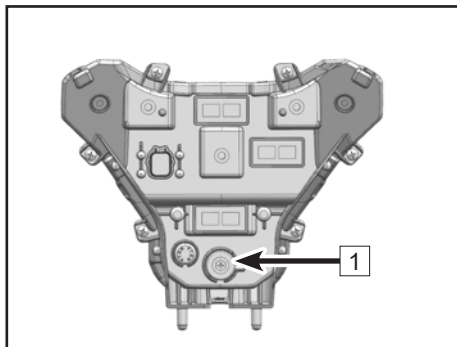

Fuses

Fuse box **1** is under the seat, it is visible after removing the seat. If a fuse is blown, inspect the electrical system for damage and replace the fuse with the new one.

⚠ WARNING

Do not use any wire to substitute for the standard fuse. Replace a blown fuse with a new one of the same ampere. Ampere value is shown on fuse.

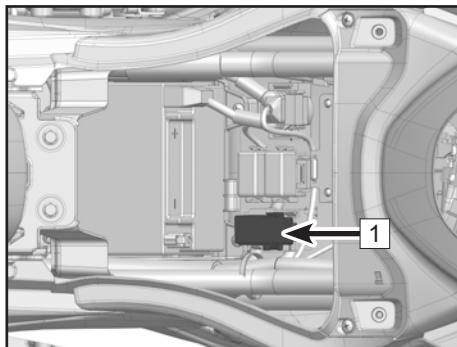

CATALYTIC CONVERTER

This motorcycle is equipped with a catalytic converter in the exhaust system. Platinum and rhodium contained inside the converter will react with carbon monoxide and convert hydrocarbons into carbon dioxide and water.

For proper operation of the catalytic converter, the following cautions must be followed:

Only use unleaded gasoline. Never use leaded gasoline which will significantly reduce the service life of the catalytic converter.

Do not let the vehicle skid when the ignition switch or the stop switch is off; Do not attempt to start the engine for a longer time when the battery is low in power. When the gear is not in Neutral, do not drag the vehicle or let the piston move. Under these improper conditions, extra unburned air/fuel mixture can flow into exhaust system, accelerating the reaction with the converter which will damage the heated engine, or reduce the converter performance when the engine is cooled off.

CAUTION

Only use unleaded gasoline. Even only a little lead can damage the precious metals inside the catalytic converter, causing catalytic converter failure. Do not add anti-rust oil or engine oil into the muffler, which may result in catalytic converter failure.

EVAPORATIVE EMISSION CONTROL SYSTEM

This vehicle is equipped with an EVAP System. Please contact a CFMOTO dealer if the EVAP System has failed. Do not modify the System, or the System will not meet requirements for environmental regulations. After disassembly and repair, tube connections should be well connected without air leakage, blocking, and tubes should be without being squeezed, broken or damaged, etc. Fuel vapors from the fuel tank are drawn into a carbon tank through an absorption tube. The fuel vapors are absorbed by active carbon in carbon tank when the engine is stopped. When the engine is running, fuel vapors absorbed in the carbon tank will flow into the engine combustion chamber and get burned, avoiding environmental pollution by preventing fuel vapors being discharged directly into the air. Meanwhile, air pressure inside the fuel tank can be balanced by the absorption tube. If inner pressure of fuel tank is lower than the outside, it can be balanced through the air tube of the carbon tank and absorption tube. In this context, all tubes should always remain clear without being blocked or squeezed, etc., and the anti-toppling valve should be mounted correctly, otherwise the fuel pump could be damaged, the fuel tank can also become deformed or broken or other parts may be damaged.

MOTORCYCLE CLEANING AND STORAGE

General Precautions

Always keeping your motorcycle clean and in best performance will extend the vehicle's service life. Protecting your motorcycle with a high quality, breathable motorcycle cover.

- Always clean the motorcycle after the engine and exhaust system have cooled.
- Avoid applying detergents on seals, brake pads, and tires.
- Clean the vehicle by hand. Do not use high-pressure spray.
- Avoid all chemicals, solvents, detergents, and household cleaning products like ammonium hydroxide.
- Gasoline, brake fluid, and coolant will damage painted surfaces. Wash them off with water immediately if splashed on any surface.
- Do not use metal brushes, steel wool, and all other abrasive pads or brushes to clean the vehicle.
- Be cautious when washing the windshield, headlight cover, and other plastic parts as they can be easily scratched.
- Avoid water-cannon, as the water may penetrate into seals and electrical components to damage the vehicle.
- Avoid spraying water into No-water areas such as air intakes, fuel system, electrical components, muffler outlets and the fuel tank lock.

Washing the Vehicle

- Rinse the vehicle with cold water to remove any loose dirt.
- Mix a bucket of detergent (specialized for motorcycles or automobiles) with water. Use a soft cloth or sponge to wash your motorcycle. If necessary, use a mild degreaser to remove any oil or grease. Start at the top of the motorcycle and wash bottom parts last.
- After washing, rinse your motorcycle with clean water to remove any residue (residue from the detergent can damage the components of your motorcycle).
- Dry off your motorcycle with a soft cloth and inspect it for any scratches.
- Start the engine and allow it to idle for several minutes. The heat from the engine will help dry off the vehicle in moist areas.
- Carefully ride the motorcycle at low speed and apply the brake several times. This will help to dry the brakes and restore their normal operating performance.
- Lubricate the drive chain to prevent rusting.

NOTE:

When riding in areas where the roads are salted or near the ocean, clean the motorcycle after your ride with cold water immediately. Do not use warm water to wash your vehicle as it accelerates the chemical reaction of the salt. After drying the vehicle, applying an anti-rust and anti-corrosion oil to all metal unpainted surfaces. In the case of riding during a rainy day or just washing the motorcycle, spray may form on the inside of the headlight shade. If this happens, start the engine and turn on the headlight to remove the moisture.

Decorating the Surface

After washing your motorcycle, polish the painted metal and plastic surfaces with a specialized motorcycle/ automobile wax. Wax should be applied every three months or as required, to avoid the surface from having satin lines or being lackluster. Always use non-abrasive wax and apply them according to the instructions.

Windshield and Other Plastic Parts

After washing, use a soft cloth to gently dry off plastic parts. When the motorcycle is dry, use specified cleaning or glazing procedures for windshield glass, light shades and other uncoated plastic parts.

CAUTION

Plastic parts may deteriorate and break if they are exposed to chemical substances or household cleaning products such as gasoline, brake fluid, window cleaners, thread fastening glue, or other chemicals. If a plastic part is exposed to any chemical substance, wash it off with water immediately, and then inspect for damage. Avoid using abrasive pads or brushes to clean surfaces of plastic parts, as they will damage their luster.

Chrome and Aluminum

Chromium alloy and unpainted aluminum parts exposed to the air can oxidize, and thus will be lackluster. These parts should be cleaned with a detergent and polished with a lustering agent. Painted and unpainted aluminum wheels should be cleaned with specialized detergents.

Leather, Vinyl, and Rubber Products

If your motorcycle has leather accessories, use specialized detergents to clean them. Washing leather accessories with detergents and water will damage them and shorten their life.

Vinyl parts should be cleaned separately.

Tires and other rubber components should be treated with a rubber protective agent to prolong their life.

⚠ DANGER

Special care must be given to tires, and it should be noted that rubber-protective agents applied to tires will not affect their functions. If tires are not treated properly, it may decrease the adhesive force between the tire and ground, possibly causing a loss of control.

Preparation for Storage

Clean the entire vehicle thoroughly.

Run the engine for about 5 minutes, stop the engine, then empty all engine oil.

⚠ DANGER

Motorcycle oil is toxic. Dispose of used oil properly. Keep the used oil out of reach of children. If skin touches the oil it should be washed off immediately.

Replenish new engine oil.

Replenish fuel and fuel additive.

⚠ DANGER

Gasoline is extremely flammable and explosive under certain conditions. Turn the ignition key to position before operation. Do not smoke. Make sure the area is well ventilated and free of any source of flame or sparks and any appliance with a pilot light. Gasoline is a toxic substance. Dispose of gasoline properly. Keep the used oil out of reach of children. If skin touches the oil it should be treated immediately.

Reduce tire pressure at least by 20% during storage period.

Raise wheels off the ground using wood boards to keep the vehicle away from moisture.

Spray a film of engine oil on all unpainted metal surfaces to prevent rusting. Avoid spraying on rubber parts or on the brakes.

Lubricate drive chains and all cables.

Remove the battery. Store it in a cool and ventilated place. Ensure that the battery is fully charged according to the Periodic Maintenance Chart.

Wrap plastic bags over the muffler exhaust pipe to prevent moisture from entering.

Put a cover over the motorcycle to prevent dust and dirt.

Preparation After Storage

Remove the plastic bags from the muffler;

Charge the battery if necessary, then mount the battery;

Do all daily safety inspections;

Lubricate any pivot points as necessary;

Take a test ride.

COMMON PROBLEMS AND CAUSES

Problem	Component	Cause	Solution
Failed engine	Fuel system	No fuel in fuel tank	Refuel
		Pump blockage or damage: poor fuel quality	Clean or replace
	Ignition system	Spark plug failure: excessive carbon deposits, too long-time usage	Inspect or replace
		Spark plug cap failure: Poor contact or burning	Inspect or replace
		Ignition coil failure: poor contact or burning	Inspect or replace
		ECU failure: Poor contact or burning	Inspect or replace
		Trigger coil failure: poor contact or burning	Inspect or replace
		Stator failure: poor contact or burning	Inspect or replace
		Wiring failure: poor contact	Inspect or adjust
	Cylinder system	Starting mechanism failure: worn or damaged	Inspect or replace
		Intake and exhaust valves, and valve seats failure: too much fuel colloidal or too long-time use	Inspect or replace
		Cylinder, piston, piston ring failure: too much fuel colloidal or wear	Inspect or replace
		Intake pipe leakage: too long-time use	Inspect or replace
		Valve timing failure	Inspect or replace

Insufficient power	Valve and piston	Intake and exhaust valves, excessive carbon deposits in the piston: poor fuel quality and poor oil quality	Repair or replace
	Clutch	Clutch slips; poor oil quality, too long-time use and overloading	Adjust or replace
	Cylinder and ring	Cylinder, piston rings wear; poor oil quality and too long-time use	Replace oil
	Brake	Incomplete separation of brake; too-tight brake	Adjust
	Main chain	Too-tight drive chain; improper adjustment	Adjust
	Engine	Engine overheating; too-rich or too-lean mixture, poor oil and fuel quality, shelters, etc	Adjust or replace
Insufficient power	Spark plug	Improper spark plug clearance	Adjust or replace
	Intake pipe	Air leakage of intake pipe; too long-time use	Adjust or replace
	Cylinder head	Air leakage for cylinder head or valves	Inspect or replace
	Electric system	Electrical system failure	Inspect or repair
	Air filter	Air filter clogging	Clean or adjust
Failed headlights and taillights	Cables	Poor connections	Adjust
	Left and right switches	Poor switch contact or switch damage	Adjust or replace
	Headlight	Bulb and lamp holder failure or damage	Adjust or replace
	Regulator	Poor connection or burning	Inspect or replace
	Magneto	Poor connection or burning	Inspect or replace

Failed horn	Battery	No electricity	Charge or replace
	Left switch	Horn button failure or damage	Adjust or replace
	Cables	Poor contact	Adjust or repair
	Horn	Horn damage	Adjust or replace

The listed above are the common problems of a motorcycle. If your motorcycle has certain problems (especially in the electronic fuel injection system, fuel evaporation system), please contact an authorized CFMOTO dealer to inspect and repair the vehicle in time.

 DANGER

Do not try to fix the problems without professional help, otherwise there may be safety risks or accidents. The user shall be responsible for any accident related to any repairs or maintenance not performed by a CFMOTO dealer.

GENERAL TORQUE CHART

Type	Torque (N•m)	Type	Torque (N•m)
M5 bolt and nut	5 ± 1	M5 screw	4 ± 1
M6 bolt and nut	10 ± 1	M6 screw	9 ± 1
M8 bolt and nut	20 ~ 30	M6 flange bolt and nut	12 ± 1
M10 bolt and nut	30 ~ 40	M8 flange bolt and nut	20 ~ 30
M12 bolt and nut	40 ~ 50	M10 flange bolt and nut	30 ~ 40

CRUCIAL TORQUE CHART

Type	Thread	Number	Tightening Torque (N•m)	Thread-locker
Engine LH front mounting bolt	M10 × 1.5 × 70	1	45~50	Yes
Engine RH front mounting bolt	M10 × 1.5 × 22	1	45~50	Yes
Engine RH middle mounting bolt	M10 × 1.5 × 22	1	45~50	Yes
Engine LH middle mounting bolt	M10 × 1.5 × 45	1	45~50	Yes
Engine rear upper mounting bolt	M10 × 1.25 × 150	1	45~50	Yes
Engine rear lower mounting bolt	M10 × 1.25 × 170	1	45~50	Yes
Sub-frame mounting bolt	M10 × 1.25 × 20	4	40~50	Yes
Upper or lower triple clamp and shock absorbers tightening bolt	M8 × 1.25 × 30	6	20 ~ 25	Yes
Upper triple clamp steering column locking bolt	M8 × 1.25 × 30	1	20 ~ 25	Yes

Upper triple clamp upper side tightening screw	M25 × 1.5	1	20 ~ 25N.m (Before lock the upper triple clamp shock absorbers tightening bolt)	No
Front shock absorber lower side and front axle tightening screw	M8 × 25	2	20 ~ 25	Yes
Rear shock absorber upper side and frame connecting bolt	M10 × 1.25 × 50	1	45~50	No
Rear shock absorber lower side and A-shape swing arm connecting bolt	M10 × 1.25 × 50	1	45~50	No
A-shape swing arm upper side and rear fork connecting bolt	M12 × 1.25 × 80	1	60	No
A-shape swing arm lower side and rod connecting bolt	M12 × 1.25 × 110	1	60	No
Rod assy and frame connecting bolt	M10 × 1.25 × 130	1	45~50	Yes
Front axle	M16 × 1.5	1	75 ~ 85	No
Tooth ring, brake disc and rim bolt	M8 × 28	9	25 ~ 30	Yes
Brake pipe and front caliper bolt	M10 × 1.0	1	38 ~ 42	No
Front caliper and front shock absorber bolt	M10 × 1.25	2	40 ~ 45	Yes
Brake pipe and hand pump bolt	M10 × 1.0	1	38 ~ 42	No
Brake pipe and ABS bolt	M10 × 1.0	4	38 ~ 42	No

Brake pipe and rear caliper bolt	M10 × 1.0	1	38 ~ 42	No
Brake pipe and foot pump bolt	M10 × 1.0	1	38 ~ 42	No
Rear brake master cylinder and RH front footrest bracket bolt	M6 × 25	2	10	Yes
Rear fluid reservoir and frame bolt	M6 × 16	1	8	No
Brake pedal lever assy and right footrest bracket bolt	M8 × 25	1	25	Yes
Hand bump fluid reservoir, mounting bracket tightening bolt	M8 × 1.25	1	25	Yes
Tightening handlebar lower bracket screw	M10 × 60	2	45	No
Tightening handlebar upper bracket screw	M8 × 25	4	20	No
Balancing block mounting screw	M8 × 50	2	20	No
Rear axle tightening nut	M16 × 1.5	1	105 ~ 110	No
Big sprocket tightening bolt	M8 × 30	6	35 ~ 40	No
Gearshift swing arm and engine axle tightening bolt	M6 × 22	1	Until tightened	Yes
Joint bearing and gearshift pedal and swing arm bolt	M6 × 16	2	6	Yes
Gearshift connecting rod adjusting nut	M6/M6LH	2	6	No

Gearshift pedal and front footrest bracket bolt	M8 × 25	1	20	Yes
Gearshift pedal and footrest connecting bolt	M8	1	25	Yes
Front pedal bracket and rear fork shaft bolt	M12 × 35	2	110	No
Front footrest bracket and frame bolt	M8 × 30	2	25	Yes
Rear footrest bracket and frame bolt	M8 × 20	4	25	Yes
Reservoir mounting bolt	M6 × 25	2	9	No
Radiator lower side and connecting bracket assy bolt	M6 × 25	1	5	No
Radiator upper side and connecting bracket bolt	M8 × 30	1	20	No
Front brake caliper mounting bolt	M10 × 1.25 × 60	2	45 ~ 50	Yes

TELEMATICS BOX

T-BOX is an optional part, and when you purchase a vehicle, you'd better check with dealer if it's equipped with a telematics box, or T-BOX.

The T-Box is an intelligent vehicle terminal that builds a communication bridge between owners and vehicles through the CFMOTO RIDE APP installed on a mobile device. The CFMOTO RIDE APP is available for download from the Apple App Store for iPhone or Google Play for Android.



Scan the QR code to download
CFMOTO RIDE APP

6AQV-380101-5100-12 EU234

ZHEJIANG CFMOTO POWER CO.,LTD

No.116,Wuzhou Road,Yuhang Economic Development Zone,
Hangzhou 311100,Zhejiang Province,China

☎ 86-571-86258863

☎ +86-571-89265788

✉ service@cfmoto.com.cn

🌐 <http://global.cfmoto.com>